

Common-Mode Chokes TCM Series



TCM range

ID Code	Inductor Range (I_{dc} +20% ripple)
TCM14 xxx H	0.3A/12mH \Rightarrow 2A/1.1mH
TCM17 xxx H	0.4A/39mH \Rightarrow 4A/0.7mH
TCM22 xxx H	0.3A/47mH \Rightarrow 4A/1.5mH
TCM28 xxx H	0.6A/47mH \Rightarrow 2.5A/3.3mH
TCM18 xxx V	0.3A/12mH \Rightarrow 2A/1.1mH
TCM19 xxx V	0.4A/39mH \Rightarrow 4A/0.7mH
TCM23 xxx V	0.3A/47mH \Rightarrow 4A/1.5mH

TCM 14

ID Code	Current (A)	Inductance value (mH)	Rdc Typ (m Ω)
TCM14 12M H	0.3	12	1275
TCM14 4M4 H	0.6	4,4	385
TCM14 3M0 H	1	3	205
TCM14 1M6 H	1.5	1.6	100
TCM14 1M1 H	2	1.1	70
TCM19 xxx V	0.8	10	0.20
TCM23 xxx V	1.2	6,8	0.15

TCM 17

ID Code	I_n (A)	Inductance value (mH)	Rdc Typ (m Ω)
TCM17 39M H	0,4	39	1460
TCM17 27M H	0,5	27	1250
TCM17 15M H	0,6	15	465
TCM17 10M H	0,8	10	370
TCM17 6M8 H	1,2	6,8	245
TCM17 3M3 H	1,5	3,3	135
TCM17 1M8 H	2	1,8	75
TCM17 M70 H	4	0,7	27

Benefits

- Designed and qualified for aerospace
- Through Hole package
- RMS current range from 0.3 A to 4 A
- Dielectric withstanding strength 1500 V_{AC}
- Materials meet UL94-V0 rating
- Operating temperature range: -55°C +125°C
- High mechanical resistance

Applications

Aeronautic, Industry, Defense, Railway

Typical Dimensions (mm)

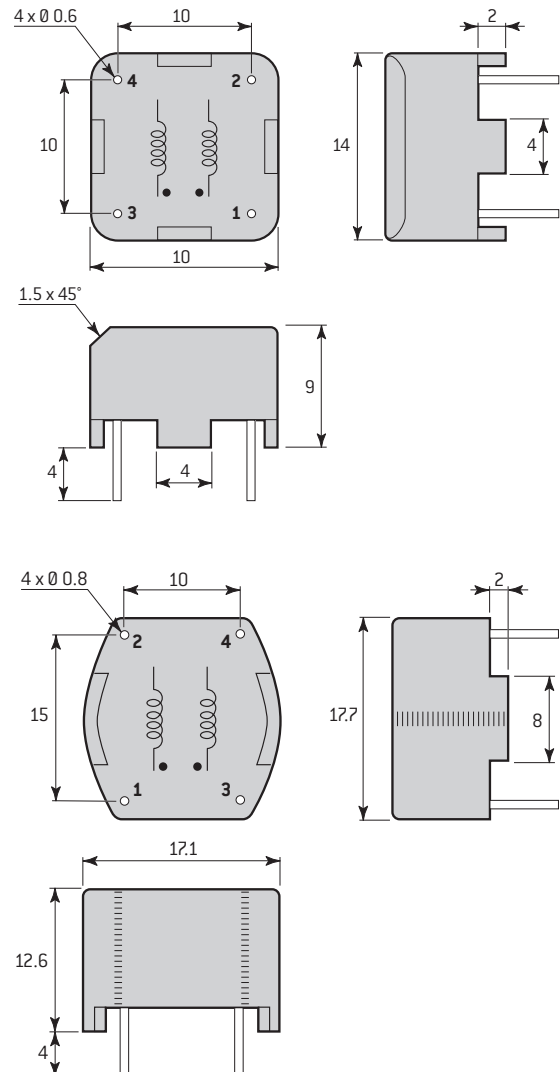

Common-Mode Chokes TCM Series

Typical Dimensions (mm)

TCM 22

ID Code	In (A)	Inductance value (mH)	Rdc Typ (mΩ)
TCM22 47M H	0.3	47	1750
TCM22 39M H	0.5	39	810
TCM22 27M H	0.8	27	500
TCM22 15M H	1	15	375
TCM22 10M H	1.2	10	200
TCM22 6M8 H	1.5	6.8	130
TCM22 4M2 H	2	4.2	102
TCM22 3M3 H	2.5	3.3	72
TCM22 2M0 H	3	2	55
TCM22 1M5 H	4	1.5	35

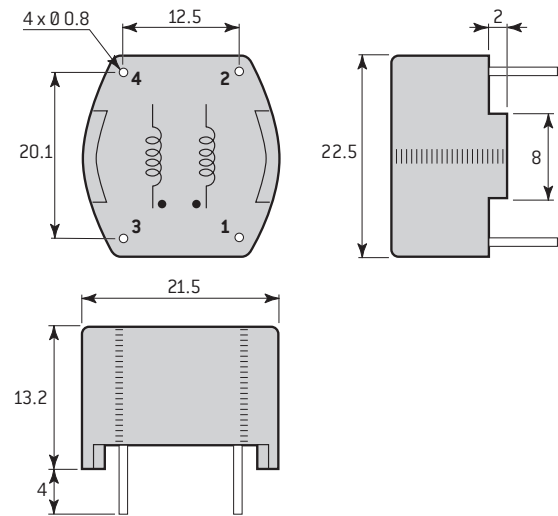

TCM 28

ID Code	In (A)	Inductance value (mH)	Rdc Typ (mΩ)
TCM28 47M H	0.6	47	1180
TCM28 39M H	0.8	39	1000
TCM28 18M H	1	18	610
TCM28 10M H	1.5	10	220
TCM28 6M8 H	2	6.8	147
TCM28 5M6 H	2.5	5.6	105
TCM28 4M5 H	3	4.5	80
TCM28 3M3 H	4	3.3	45

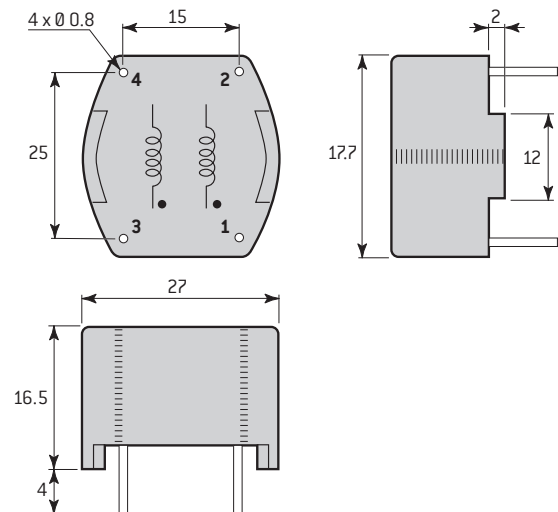

TCM 18

ID Code	In (A)	Inductance value (mH)	Rdc Typ (mΩ)
TCM18 12M V	0.3	12	1275
TCM18 4M4 V	0.6	4.4	385
TCM18 3M0 V	1	3	205
TCM18 1M6 V	1.5	1.6	100
TCM18 1M1 V	2	1.1	70

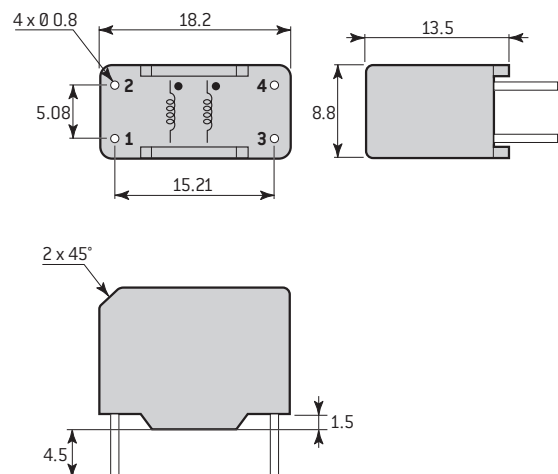

STANDARD PRODUCTS

Common-Mode Chokes TCM Series

Typical Dimensions (mm)

TCM 19

ID Code	In (A)	Inductance value (mH)	Rdc Typ (mΩ)
TCM19 39M V	0.4	39	1460
TCM19 27M V	0.5	27	1250
TCM19 15M V	0.6	15	465
TCM19 10M V	0.8	10	370
TCM19 6M8 V	1.2	6.8	245
TCM19 3M3 V	1.5	3.3	135
TCM19 1M8 V	2	1.8	75
TCM19 0M7 V	4	0.7	27

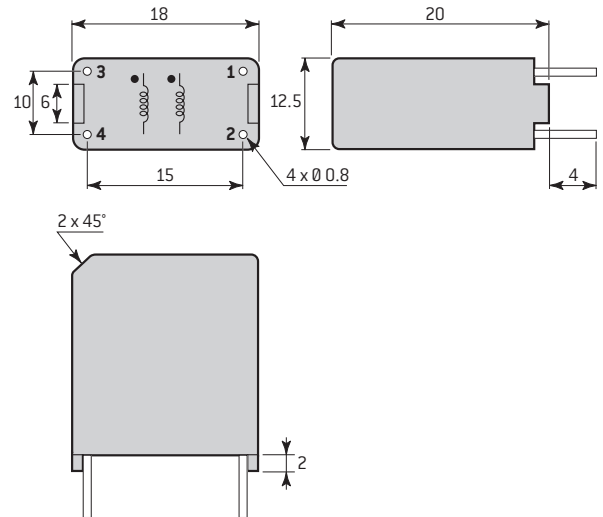

TCM 23

ID Code	In (A)	Inductance value (mH)	Rdc Typ (mΩ)
TCM23 47M V	0.3	47	1750
TCM23 39M V	0.5	39	810
TCM23 27M V	0.8	27	500
TCM23 15M V	1	15	375
TCM23 10M V	1.2	10	200
TCM23 6M8 V	1.5	6.8	130
TCM23 4M2 V	2	4.2	102
TCM23 3M3 V	2.5	3.3	72
TCM23 2M0 V	3	2	55
TCM23 1M5 V	4	1.5	35

