

Miniature Chip Inductors MPCI 10000 Series



Electrical Data (25°C)

ID Code	Induct.* μH	Q Min.	Q Typ.	Test Freq. MHz	SFR Min. MHz	R _{DC} max. Ω	DC Curr. mA max	Tol** %
MPCI 10 000 010	0.010	50	55	150	2000	0.025	750	10
MPCI 10 000 012	0.012	50	55	150	2000	0.025	750	
MPCI 10 000 015	0.015	50	55	150	1800	0.040	750	
MPCI 10 000 018	0.018	50	55	150	1500	0.040	750	
MPCI 10 000 022	0.022	45	50	100	1400	0.040	750	
MPCI 10 000 027	0.027	45	50	100	1200	0.040	750	
MPCI 10 000 033	0.033	47	55	100	1200	0.050	640	
MPCI 10 000 039	0.039	47	55	100	1200	0.070	600	
MPCI 10 000 047	0.047	47	55	100	1000	0.080	550	
MPCI 10 000 056	0.056	47	55	100	900	0.090	520	
MPCI 10 000 068	0.068	47	55	100	900	0.10	480	
MPCI 10 000 082	0.082	47	55	100	750	0.11	470	
MPCI 10 000 100	0.100	47	55	50	700	0.11	470	
MPCI 10 000 120	0.120	47	55	50	600	0.11	470	
MPCI 10 000 150	0.150	47	55	50	500	0.12	450	
MPCI 10 000 180	0.180	51	60	50	450	0.14	430	
MPCI 10 000 220	0.220	51	60	50	420	0.20	350	
MPCI 10 000 270	0.270	51	60	50	400	0.25	310	
MPCI 10 000 330	0.330	51	60	50	320	0.30	280	
MPCI 10 000 390	0.390	47	55	50	270	0.45	240	
MPCI 10 000 470	0.470	47	55	25	250	0.50	230	
MPCI 10 000 560	0.560	52	60	25	200	0.55	220	

- eesa qualified 3201/008 and in accordance to Mil Spec M83446/5
- Excellent Q values even at high frequencies
- Very high self-resonant frequencies (SFRs)
- Extremely stable inductance values from -55°C to +125°C
- With or without tab terminations
- Tin / lead (non RoHS) or gold plated (RoHS) terminations
- Frequency range: 7.9 MHz to 500 MHz
- Operating temperature range: -55°C to +125°C
- Weight: 0.07 gram
- MSL level: 1

ID Code	Induct.* μH	Q Min	Q Typ.	Test Freq. MHz	SFR Min. MHz	R _{DC} max. Ω	DC Curr. mA max	Tol** %
MPCI 10 000 680	0.680	52	60	25	180	0.58	210	5-10
MPCI 10 000 820	0.820	52	60	25	150	0.60	200	
MPCI 10 001 000	1.00	52	60	25	120	0.65	190	
MPCI 10 001 200	1.20	42	50	7.90	110	0.75	180	
MPCI 10 001 500	1.50	42	50	7.90	100	1.10	160	
MPCI 10 001 800	1.80	48	55	7.90	95	1.20	150	
MPCI 10 002 200	2.20	48	55	7.90	90	1.30	140	
MPCI 10 002 700	2.70	48	55	7.90	65	1.50	130	
MPCI 10 003 300	3.30	48	55	7.90	55	1.80	120	
MPCI 10 003 900	3.90	48	55	7.90	45	2.00	110	
MPCI 10 004 700	4.70	48	55	7.90	43	2.30	100	
MPCI 10 005 600	5.60	48	55	7.90	40	2.50	100	
MPCI 10 006 800	6.80	46	53	7.90	38	2.60	98	
MPCI 10 008 200	8.20	46	53	7.90	35	2.80	95	
MPCI 10 010 000	10.0	46	53	7.90	33	3.30	87	

* Standard inductance tolerance: ± 10 %

** Available tolerances.

Other inductance values on request.

Inductance variation: 35 PPM/°C max. in the range 0.01 to 12 H
80 PPM/°C max. in the range 1.5 to 10 μH

Packaging

Tape and Reel (with or without tab): 100 pieces min. up to 500 pieces or Tray: 81 pieces without tab, 49 pieces with tab

Typical Dimensions (mm)

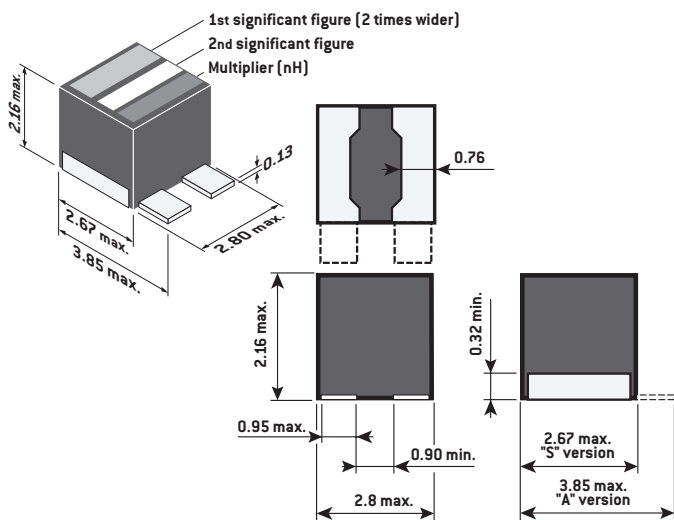

Q vs frequency

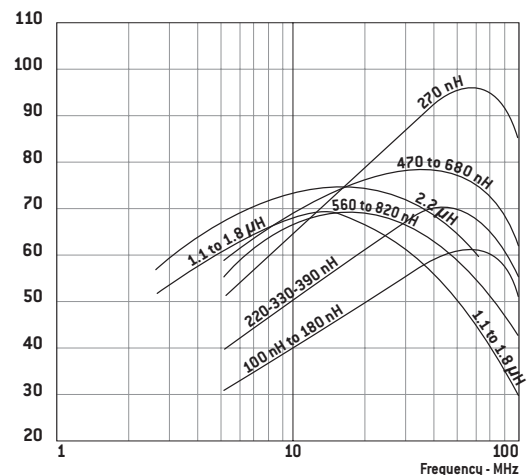

Miniature Chip Inductors MSCI 10000 Series



MPCI 10000 series are usually installed on Military applications and breadboards for Space applications.

Since January 2003, EXXELIA has been manufacturing Radio Frequency Fixed Coils, MPCI 10000 series fulfilling ESA ESCC Generic specification N° 3201 and detail specification N° 3201/008.

This range is named MSCI (S for space applications).

This qualification approval includes final production tests Chart F2, burn-in and electrical measurements to testing Chart F3 and qualification testing Chart F4.

For procurement, different quality levels are offered:

- Final production tests Chart F2
- Burn-in and electrical measurements Chart F3
- Lot acceptance testing Chart F4 if required

Components delivered through this specification need to be processed and inspected in accordance with the EXXELIA Process Identification Document (P.I.D.).

Each component delivered is traceable to its production lot. max. 500 pieces per lot.

Cross reference chart

EXXELIA Non - QPL ID Code	EXXELIA QPL ID Code	ESA SCC Component Part Number	In accordance to MIL-PRX-83446 Part Number	
			* Tin lead (F) or * Gold lead (A) with tab	* Tin lead (F) or * Gold lead (A) without tab
MPCI 10 000 010 x y 10	MSCI 10 000 010 x y 10	3201008 aa L010 K	M83446/5-01*	M83446/5-38*
MPCI 10 000 012 x y 10	MSCI 10 000 012 x y 10	3201008 aa L012 K	M83446/5-02*	M83446/5-39*
MPCI 10 000 015 x y 10	MSCI 10 000 015 x y 10	3201008 aa L015 K	M83446/5-03*	M83446/5-40*
MPCI 10 000 018 x y 10	MSCI 10 000 018 x y 10	3201008 aa L018 K	M83446/5-04*	M83446/5-41*
MPCI 10 000 022 x y 10/5	MSCI 10 000 022 x y 10/5	3201008 aa L022 K/J	M83446/5-05*	M83446/5-42*
MPCI 10 000 027 x y 10/5	MSCI 10 000 027 x y 10/5	3201008 aa L027 K/J	M83446/5-06*	M83446/5-43*
MPCI 10 000 033 x y 10/5	MSCI 10 000 033 x y 10/5	3201008 aa L033 K/J	M83446/5-07*	M83446/5-44*
MPCI 10 000 039 x y 10/5	MSCI 10 000 039 x y 10/5	3201008 aa L039 K/J	M83446/5-08*	M83446/5-45*
MPCI 10 000 047 x y 10/5	MSCI 10 000 047 x y 10/5	3201008 aa L047 K/J	M83446/5-09*	M83446/5-46*
MPCI 10 000 056 x y 10/5	MSCI 10 000 056 x y 10/5	3201008 aa L056 K/J	M83446/5-10*	M83446/5-47*
MPCI 10 000 068 x y 10/5	MSCI 10 000 068 x y 10/5	3201008 aa L068 K/J	M83446/5-11*	M83446/5-48*
MPCI 10 000 082 x y 10/5	MSCI 10 000 082 x y 10/5	3201008 aa L082 K/J	M83446/5-12*	M83446/5-49*
MPCI 10 000 100 x y 10	MSCI 10 000 100 x y 10	3201008 aa L10 K	M83446/5-13*	M83446/5-50*
MPCI 10 000 120 x y 10	MSCI 10 000 120 x y 10	3201008 aa L12 K	M83446/5-14*	M83446/5-51*
MPCI 10 000 150 x y 10	MSCI 10 000 150 x y 10	3201008 aa L15 K	M83446/5-15*	M83446/5-52*
MPCI 10 000 180 x y 10	MSCI 10 000 180 x y 10	3201008 aa L18 K	M83446/5-16*	M83446/5-53*
MPCI 10 000 220 x y 10	MSCI 10 000 220 x y 10	3201008 aa L22 K	M83446/5-17*	M83446/5-54*
MPCI 10 000 270 x y 10	MSCI 10 000 270 x y 10	3201008 aa L27 K	M83446/5-18*	M83446/5-55*
MPCI 10 000 330 x y 10	MSCI 10 000 330 x y 10	3201008 aa L33 K	M83446/5-19*	M83446/5-56*
MPCI 10 000 390 x y 10	MSCI 10 000 390 x y 10	3201008 aa L39 K	M83446/5-20*	M83446/5-57*
MPCI 10 000 470 x y 10/5	MSCI 10 000 470 x y 10/5	3201008 aa L47 K/J	M83446/5-21*	M83446/5-58*
MPCI 10 000 560 x y 10/5	MSCI 10 000 560 x y 10/5	3201008 aa L56 K/J	M83446/5-22*	M83446/5-59*
MPCI 10 000 680 x y 10/5	MSCI 10 000 680 x y 10/5	3201008 aa L68 K/J	M83446/5-23*	M83446/5-60*
MPCI 10 000 820 x y 10/5	MSCI 10 000 820 x y 10/5	3201008 aa L82 K/J	M83446/5-24*	M83446/5-61*
MPCI 10 001 000 x y 10/5	MSCI 10 001 000 x y 10/5	3201008 aa 1L0 K/J	M83446/5-25*	M83446/5-62*
MPCI 10 001 200 x y 10/5/2	MSCI 10 001 200 x y 10/5/2	3201008 aa 1L2 K/J/G	M83446/5-26*	M83446/5-63*
MPCI 10 001 500 x y 10/5/2	MSCI 10 001 500 x y 10/5/2	3201008 aa 1L5 K/J/G	M83446/5-27*	M83446/5-64*
MPCI 10 001 800 x y 10/5/2	MSCI 10 001 800 x y 10/5/2	3201008 aa 1L8 K/J/G	M83446/5-28*	M83446/5-65*
MPCI 10 002 200 x y 10/5/2	MSCI 10 002 200 x y 10/5/2	3201008 aa 2L2 K/J/G	M83446/5-29*	M83446/5-66*
MPCI 10 002 700 x y 10/5/2	MSCI 10 002 700 x y 10/5/2	3201008 aa 2L7 K/J/G	M83446/5-30*	M83446/5-67*
MPCI 10 003 300 x y 10/5/2	MSCI 10 003 300 x y 10/5/2	3201008 aa 3L3 K/J/G	M83446/5-31*	M83446/5-68*
MPCI 10 003 900 x y 10/5/2	MSCI 10 003 900 x y 10/5/2	3201008 aa 3L9 K/J/G	M83446/5-32*	M83446/5-69*
MPCI 10 004 700 x y 10/5/2	MSCI 10 004 700 x y 10/5/2	3201008 aa 4L7 K/J/G	M83446/5-33*	M83446/5-70*
MPCI 10 005 600 x y 10/5/2	MSCI 10 005 600 x y 10/5/2	3201008 aa 5L6 K/J/G	M83446/5-34*	M83446/5-71*
MPCI 10 006 800 x y 10/5/2	MSCI 10 006 800 x y 10/5/2	3201008 aa 6L8 K/J/G	M83446/5-35*	M83446/5-72*
MPCI 10 008 200 x y 10/5/2	MSCI 10 008 200 x y 10/5/2	3201008 aa 8L2 K/J/G	M83446/5-36*	M83446/5-73*
MPCI 10 010 000 x y 10/5/2	MSCI 10 010 000 x y 10/5/2	3201008 aa 100 K/J/G	M83446/5-37*	M83446/5-74*

aa = 01 for Au Termination
aa = 02 for SnPb Termination

To Order

MPCI	10	####	x	y	z
Radio Frequency Fixed Coils	Size	Inductance Value [nH] from 000 010 to 010 000	Terminations x = G for Gold x = T for SnPb	Terminations shape y = S without tab y = A with tab (Not valid for space use)	Tolerance: z = 10 ±10% z = 5 ±5% z = 2 ±2%

MPCI 10 ### ## x y z