

FELSIK 105

BC - BD

8 000 h / 105°C

16 V ... 450 V	100 μ F ... 470 000 μ F	\emptyset 36 [1,417] ... \emptyset 90 [3,543]	- 55°C + 105°C	Long Life Time
----------------	---------------------------------	---	----------------	----------------

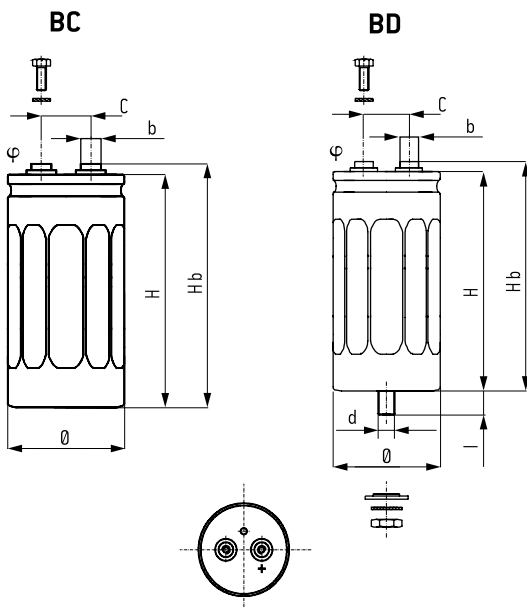

HEXAGONAL SCREWS mm (inches)

Screwing height between screws and terminals:
3,5 [0,138] max

Max. screw torque: M5: 3 Nm [x min 8 [0,315]]
M6: 6 Nm [x min 10 [0,394]]

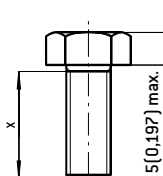

SPECIFICATIONS

NFC 83 110

DIN 40 040 - Climatic category FMD - 55°C + 105°C / 56 days

CECC 30301-803 Issue 2 - European standard

IEC 60 384.4 - Long life

Standard endurance test at U_R : 2000 h / 105°C
5000 h / 85°C

APPLICATIONS

- Power electronics: converters, current inverters
- Switch mode power supplies
- Magnetization, welding machines, flash
- Circuit with high impulse current

Fixing: Clip or stud fixing

Screw terminals: M5 or M6

Tolerance on capacitance at 20°C: -10 +30 %

Operating temperature: - 55°C + 105°C

BC	BD
Insulated aluminum can	Aluminum can with sleeve
Hexagonal screws	Hexagonal screws
Spring washers	Spring washers
Fixing clip must be ordered separately	Stud fixing delivered with capacitor [steel hex nut, spring washer]

DIMENSIONS in mm (inches)

\emptyset ± 1 (0,039)	H ± 2 (0,079)	Hb ± 2 (0,079)	c $\pm 0,5$ (0,020)	ϕ	b
36 [1,417]	52 [2,047]	58 [2,283]	12,7 [0,500]	M5	8 [0,315]
36 [1,417]	60 [2,362]	66 [2,598]	12,7 [0,500]	M5	8 [0,315]
36 [1,417]	80 [3,150]	86 [3,386]	12,7 [0,500]	M5	8 [0,315]
36 [1,417]	104 [4,094]	110 [4,331]	12,7 [0,500]	M5	8 [0,315]
51 [2,008]	81 [3,189]	87 [3,425]	22,2 [0,874]	M5	13 [0,512]
51 [2,008]	104 [4,094]	110 [4,331]	22,2 [0,874]	M5	13 [0,512]
66 [2,598]	104 [4,094]	110 [4,331]	28,5 [1,122]	M5	13 [0,512]
77 [3,031]	104 [4,094]	110 [4,331]	31,7 [1,248]	M5	13 [0,512]
77 [3,031]	144 [5,669]	150 [5,906]	31,7 [1,248]	M5	13 [0,512]
77 [3,031]	220 [8,661]	226 [8,898]	31,7 [1,248]	M5	13 [0,512]
90 [3,543]	144 [5,669]	151 [5,945]	31,7 [1,248]	M6	13 [0,512]
90 [3,543]	200 [7,874]	207 [8,150]	31,7 [1,248]	M6	13 [0,512]

\emptyset	d	l	Max. nut torque
36 [1,417]	M8	12 ± 1 [0,472 $\pm 0,472$]	4 Nm
≥ 51 [2,008]	M12	16 $\pm 1,5$ [0,630 $\pm 0,059$]	10 Nm

RESISTANCE TO VIBRATIONS

Hb mm (inches)	>150 [5,906]	≤ 150 [5,906]
f (Hz)	10 - 55 Hz	10 - 2000 Hz
Amplitude	0,75 [0,030]	1,5 [0,059]
Acceleration	10 g - 98 m/s ²	20 g - 196 m/s ²
t (h)	3 x 2 h	3 x 2 h

WITHSTAND STRENGTH OF INSULATING SLEEVE

Insulation resistance at 20°C between terminals and mounting hardware: 100 M Ω

Test voltage at 50 Hz 1 min. between terminals and mounting hardware: 2000 V

Fire resistance: self extinguish 15 s (IEC 60 695-2-2)

FELSIC 105

BC - BD

8 000 h / 105°C

Capacitance [μ F]	Can		ESR 100 Hz +20°C		Z 10 kHz +20°C max. [m Ω]	II +20°C 5 min max. [mA]	I ~ 100 Hz			Code			
	Ø mm [inches]	H mm [inches]	Typic [m Ω]	max. [m Ω]			+40°C max. [A]	+85°C [A]	+105°C [A]	BC	BD		
Rated voltage 16 V													
10000	36	(1,417)	52	(2,047)	22	32	20	0,32	22	13	6,9	A 756040	A 757040
15000	36	(1,417)	80	(3,150)	18	26	16	0,48	22	17	9	A 756042	A 757042
22000	36	(1,417)	104	(4,094)	14	21	15	0,70	22	22	11,7	A 756044	A 757044
33000	51	(2,008)	81	(3,189)	12	18	12	1,05	25	25	13,7	A 756046	A 757046
47000	51	(2,008)	104	(4,094)	11	15	10	1,50	25	25	16	A 756047	A 757047
68000	66	(2,598)	104	(4,094)	10	14	10	2,18	50	35	18,5	A 756049	A 757049
100000	77	(3,031)	104	(4,094)	8	11	10	3,20	55	35	19,4	A 756050	A 757050
150000	77	(3,031)	144	(5,669)	7	10	9	4,80	55	41	23,8	A 756052	A 757052
Rated voltage 25 V													
4700	36	(1,417)	52	(2,047)	22	50	25	0,23	22	13	6,9	A 756080	A 757080
6800	36	(1,417)	52	(2,047)	20	30	22	0,36	22	14	7,2	A 756081	A 757081
10000	36	(1,417)	80	(3,150)	18	28	20	0,50	22	17	9	A 756083	A 757083
15000	36	(1,417)	104	(4,094)	17	25	20	0,75	22	20	10,6	A 756085	A 757085
22000	51	(2,008)	81	(3,189)	13	20	15	1,10	25	25	13,2	A 756087	A 757087
33000	51	(2,008)	104	(4,094)	11	16	12	1,65	25	25	16	A 756089	A 757089
47000	66	(2,598)	104	(4,094)	10	14	12	2,35	50	37	19,4	A 756091	A 757091
68000	77	(3,031)	104	(4,094)	7	10	8	3,40	55	37	20,6	A 756093	A 757093
100000	77	(3,031)	144	(5,669)	7	10	8	5,00	55	41	23,8	A 756095	A 757095
220000	77	(3,031)	220	(8,661)	7	10	8	6,00	55	50	28,7	A 756097	A 757097
470000	90	(3,543)	144	(5,669)	4	10	8	8,00	80	65	34	A 756098	A 757098
Rated voltage 40 V													
3300	36	(1,417)	52	(2,047)	22	50	25	0,27	22	13	6,9	A 756120	A 757120
4700	36	(1,417)	80	(3,150)	18	28	20	0,38	22	17	9	A 756121	A 757121
10000	36	(1,417)	80	(3,150)	16	24	16	0,80	22	18	9,7	A 756123	A 757123
15000	51	(2,008)	81	(3,189)	12	18	13	1,20	25	25	13,7	A 756126	A 757126
22000	51	(2,008)	104	(4,094)	11	17	12	1,76	25	25	16	A 756128	A 757128
33000	66	(2,598)	104	(4,094)	10	16	12	2,64	50	37	19,4	A 756130	A 757130
47000	77	(3,031)	104	(4,094)	7	10	10	3,76	55	37	20,6	A 756132	A 757132
68000	77	(3,031)	144	(5,669)	7	10	8	5,44	55	41	23	A 756134	A 757134
100000	77	(3,031)	144	(5,669)	5	10	8	8,00	55	48	27	A 756135	A 757135
150000	90	(3,543)	144	(5,669)	4	10	8	10,00	80	65	34	A 756137	A 757137
Rated voltage 63 V													
2200	36	(1,417)	52	(2,047)	36	54	40	0,27	20	10	5,4	A 756160	A 757160
3300	36	(1,417)	80	(3,150)	25	38	25	0,41	22	15	7,8	A 756162	A 757162
4700	36	(1,417)	104	(4,094)	22	32	22	0,59	22	18	9,3	A 756164	A 757164
6800	51	(2,008)	81	(3,189)	15	22	16	0,86	25	23	12,2	A 756166	A 757166
10000	51	(2,008)	104	(4,094)	11	16	11	1,26	25	25	16	A 756168	A 757168
15000	66	(2,598)	104	(4,094)	10	15	10	1,89	50	37	19,4	A 756170	A 757170
22000	77	(3,031)	104	(4,094)	7	11	8	2,77	55	37	20,6	A 756172	A 757172
33000	77	(3,031)	144	(5,669)	6	10	8	4,16	55	44	25,7	A 756174	A 757174
47000	77	(3,031)	144	(5,669)	6	10	8	5,92	55	44	25,7	A 756175	A 757175
68000	77	(3,031)	220	(8,661)	5	10	8	8,56	55	55	33	A 756176	A 757176
100000	90	(3,543)	144	(5,669)	4	10	8	10,00	80	65	34	A 756179	A 757179
Rated voltage 100 V													
1000	36	(1,417)	52	(2,047)	85	130	75	0,20	13	6,6	3,5	A 756200	A 757200
2200	36	(1,417)	80	(3,150)	40	60	40	0,44	22	12	6,2	A 756202	A 757202
3300	51	(2,008)	81	(3,189)	30	45	30	0,66	25	16	8,7	A 756204	A 757204
4700	51	(2,008)	104	(4,094)	27	40	24	0,94	25	19	10,2	A 756206	A 757206
6800	66	(2,598)	104	(4,094)	21	27	20	1,36	50	25	13,4	A 756208	A 757208
10000	66	(2,598)	104	(4,094)	16	23	15	2,00	50	29	15,3	A 756209	A 757209
15000	77	(3,031)	144	(5,669)	10	15	12	3,00	55	35	20	A 756211	A 757211
22000	77	(3,031)	144	(5,669)	8	12	10	4,40	55	40	23	A 756212	A 757212
33000	77	(3,031)	220	(8,661)	5	10	8	6,60	55	55	33	A 756213	A 757213
47000	90	(3,543)	144	(5,669)	4	10	8	9,00	80	65	34	A 756216	A 757216
Rated voltage 160 V													
470	36	(1,417)	52	(2,047)	120	180	100	0,15	9	4,1	2,4	A 756240	A 757240
680	36	(1,417)	80	(3,150)	70	105	60	0,21	14	6,6	3,8	A 756241	A 757241
1000	36	(1,417)	104	(4,094)	50	75	50	0,32	19	8,8	5,1	A 756242	A 757242
1500	51	(2,008)	81	(3,189)	42	63	40	0,48	23	10	6	A 756243	A 757243
2200	51	(2,008)	104	(4,094)	30	45	30	0,70	25	14	7,9	A 756245	A 757245
3300	66	(2,598)	104	(4,094)	20	30	20	1,05	42	19	11,2	A 756246	A 757246
4700	77	(3,031)	104	(4,094)	15	23	15	1,50	53	24	14,1	A 756248	A 757248
6800	77	(3,031)	144	(5,669)	10	15	11	2,18	55	38	22	A 756250	A 757250
10000	77	(3,031)	144	(5,669)	8	12	10	3,20	55	40	23	A 756251	A 757251
15000	77	(3,031)	220	(8,661)	6	10	8	4,80	55	52	30	A 756252	A 757252
15000	90	(3,543)	144	(5,669)	6	10	8	4,80	80	52	30	A 756253	A 757253

8 000 h / 105°C

Capacitance [μ F]	Can				ESR 100 Hz +20°C		Z 10 kHz +20°C max. [m Ω]	II +20°C 5 min max. [mA]	I~ 100 Hz			Code	
	Ø		H		Typic [m Ω]	max. [m Ω]			+40°C max. [A]	+85°C [A]	+105°C [A]	BC	BD
	mm [inches]	mm [inches]	mm [inches]	mm [inches]									
Rated voltage 250 V													
470	36	(1,417)	80	(3,150)	105	160	90	0,23	12	5,4	3,1	A 756281	A 757281
680	51	(2,008)	81	(3,189)	60	90	55	0,34	19	8,7	5	A 756283	A 757283
1000	51	(2,008)	81	(3,189)	45	68	42	0,50	22	10	5,8	A 756284	A 757284
1500	51	(2,008)	104	(4,094)	34	51	34	0,75	25	13	7,4	A 756286	A 757286
2200	66	(2,598)	104	(4,094)	26	39	26	1,13	37	17	9,8	A 756287	A 757287
3300	77	(3,031)	104	(4,094)	19	29	20	1,65	47	22	12,5	A 756289	A 757289
4700	77	(3,031)	144	(5,669)	10	15	11	2,35	55	34	20	A 756291	A 757291
6800	77	(3,031)	144	(5,669)	9	14	10	3,40	55	38	22	A 756292	A 757292
10000	77	(3,031)	220	(8,661)	8	12	10	4,50	55	45	26	A 756293	A 757293
15000	90	(3,543)	144	(5,669)	5	10	8	7,00	80	54	31	A 756296	A 757296
Rated voltage 350 V													
220	36	(1,417)	80	(3,150)	290	380	280	0,16	7	3,2	1,9	A 756321	A 757321
330	36	(1,417)	104	(4,094)	220	290	200	0,24	9	4,1	2,4	A 756323	A 757323
470	51	(2,008)	81	(3,189)	95	145	90	0,33	15	6,8	4	A 756325	A 757325
680	51	(2,008)	104	(4,094)	75	115	70	0,48	19	8,6	5	A 756327	A 757327
1000	51	(2,008)	104	(4,094)	65	95	65	0,70	20	9,2	5,4	A 756328	A 757328
1500	66	(2,598)	104	(4,094)	60	80	55	1,05	26	12,1	7	A 756329	A 757329
2200	77	(3,031)	104	(4,094)	30	46	34	1,50	38	17	10	A 756330	A 757330
3300	77	(3,031)	104	(4,094)	23	34	27	2,30	43	20	11,4	A 756338	A 757338
3300	77	(3,031)	144	(5,669)	20	30	25	2,30	53	24,0	14	A 756331	A 757331
4700	77	(3,031)	144	(5,669)	18	27	21	3,30	55	26,0	15	A 756332	A 757332
6000	77	(3,031)	220	(8,661)	12	20	20	4,20	55	29	17	A 756333	A 757333
6000	90	(3,543)	144	(5,669)	12	20	15	4,20	75	35	20	A 756334	A 757334
10000	90	(3,543)	200	(7,874)	10	15	12	5,00	80	43	25	A 756337	A 757337
Rated voltage 400 V													
150	36	(1,417)	60	(2,362)	380	500	400	0,12	5	2,4	1,4	A 756361	A 757361
220	36	(1,417)	80	(3,150)	260	400	350	0,18	7,5	3,5	2	A 756362	A 757362
330	36	(1,417)	104	(4,094)	195	300	250	0,27	10	4,5	2,6	A 756363	A 757363
470	51	(2,008)	81	(3,189)	140	220	150	0,38	12	5,7	3,3	A 756364	A 757364
680	51	(2,008)	104	(4,094)	100	150	100	0,55	16	7,4	4,3	A 756366	A 757366
1000	51	(2,008)	104	(4,094)	90	140	90	0,80	17	8	4,6	A 756367	A 757367
1500	51	(2,008)	104	(4,094)	65	85	60	1,20	20	9,5	5,4	A 756375	A 757375
1500	66	(2,598)	104	(4,094)	65	85	60	1,20	23	11	6,2	A 756368	A 757368
2200	77	(3,031)	104	(4,094)	40	60	45	1,80	32	15	8,6	A 756369	A 757369
3300	77	(3,031)	144	(5,669)	25	38	25	2,70	47	22,9	12,6	A 756370	A 757370
4700	77	(3,031)	220	(8,661)	20	30	20	3,80	55	28	16	A 756371	A 757371
6800	90	(3,543)	200	(7,874)	15	25	15	5,50	75	35	20	A 756374	A 757374
Rated voltage 450 V													
100	36	(1,417)	52	(2,047)	600	900	600	0,27	5	2,1	1,2	A 756400	A 757400
150	36	(1,417)	60	(2,362)	480	720	500	0,40	5	2,2	1,3	A 756401	A 757401
220	36	(1,417)	80	(3,150)	410	600	450	0,59	6	2,7	1,6	A 756402	A 757402
330	36	(1,417)	104	(4,094)	340	500	380	0,89	7	3,4	1,9	A 756403	A 757403
470	51	(2,008)	81	(3,189)	170	260	170	1,26	11	5,2	3	A 756404	A 757404
680	51	(2,008)	104	(4,094)	160	240	160	1,83	13	5,9	3,4	A 756405	A 757405
1000	66	(2,598)	104	(4,094)	70	105	70	2,70	22	10	6	A 756406	A 757406
1500	77	(3,031)	104	(4,094)	45	68	45	4,00	31	14	8,1	A 756407	A 757407
2200	77	(3,031)	144	(5,669)	30	45	30	5,90	43	20	11,5	A 756408	A 757408
3300	77	(3,031)	220	(8,661)	25	38	25	8,90	55	26	15	A 756409	A 757409
4700	77	(3,031)	220	(8,661)	20	30	23	10,00	55	29	17	A 756411	A 757411
6800	90	(3,543)	200	(7,874)	15	25	16	12,00	75	35	20	A 756413	A 757413

FELSIC 105

BC - BD

8 000 h / 105°C

PERMISSIBLE REPETITIVE PEAK CURRENT I_p :

If given corresponding max r.m.s. currents are not exceeded, peak current values are as follows

DIMENSIONS in mm (inches)				I_p (A)		$I \sim \text{max.}$ (A)
\emptyset	H			40°C	105°C	
36	(1,417)	52	(2,047)	400	200	22
36	(1,417)	60	(2,362)	450	220	22
36	(1,417)	80	(3,150)	600	300	22
36	(1,417)	104	(4,094)	700	400	22
51	(2,008)	81	(3,189)	800	400	25
51	(2,008)	104	(4,094)	1100	500	25
66	(2,598)	104	(4,094)	1900	800	50
77	(3,031)	104	(4,094)	3100	1200	55
77	(3,031)	144	(5,669)	4200	1800	55
77	(3,031)	220	(8,661)	5700	2400	55
90	(3,543)	144	(5,669)	5700	2400	80
90	(3,543)	200	(7,874)	7700	3200	80

PEAK VOLTAGE (V)

1000 cycles, without ripple current
 U_p : Repetitive standard peak voltage (30 s)
 U_s : Repetitive surge voltage (0,1 s)
 Do not overstep this value without damage.

U_R	16 V	25 V	40 V	63 V	100 V	160 V	250 V	350 V	400 V	450 V	
U_p	18	29	46	72	115	184	288	385	440	495	
U_s							235	340	450	495	540

PERMISSIBLE RIPPLE CURRENT I (R.M.S. VALUE)

versus frequency f :

$I \sim$: permissible r.m.s. current at 100 Hz

f (Hz)	50	100	300	600	1 000	10 000	50 000
I	$0,8 \times I \sim$	$I \sim$	$1,2 \times I \sim$	$1,3 \times I \sim$	$1,35 \times I \sim$	$1,5 \times I \sim$	$1,6 \times I \sim$

EXPECTED LIFE

As a function of temperature and ripple current

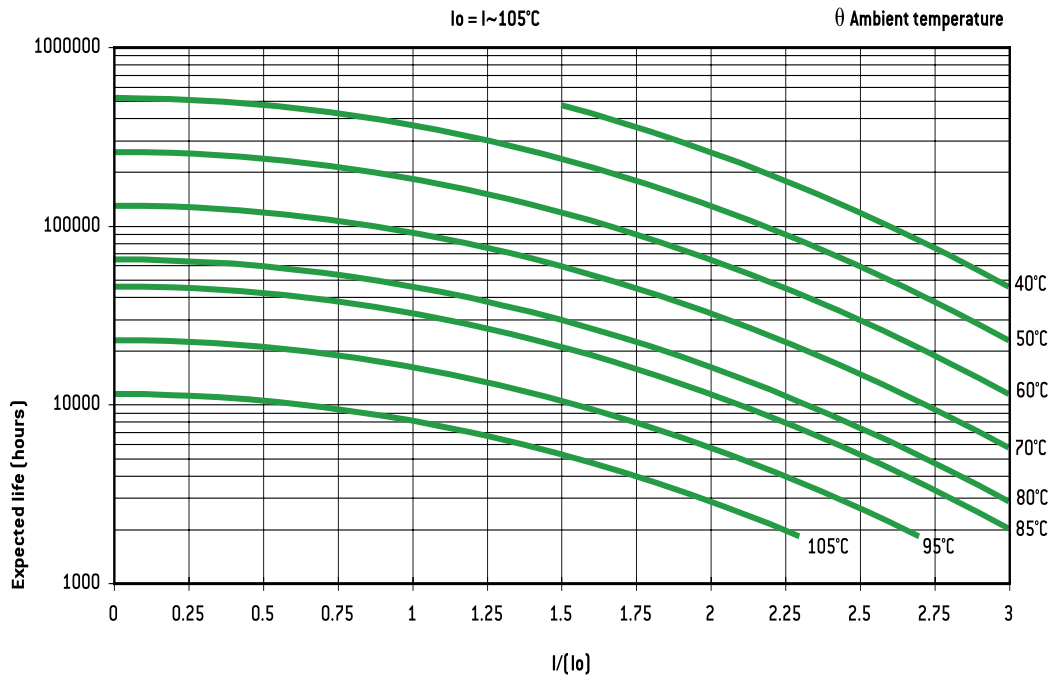

$U_R \leq 350 \text{ V}$: θ max 115°C
 $U_R > 350 \text{ V}$: θ max 105°C

General technical data

1. BASIC CONSTRUCTION

Structure of an electrolytic aluminum capacitor is shown hereunder:

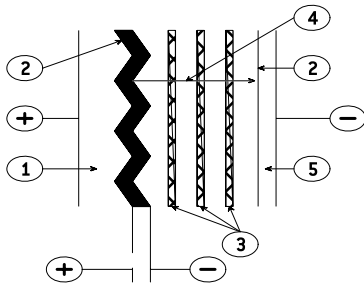

1. Anode: aluminum foil
2. Dielectric: aluminum oxide
3. Papers spacers impregnated with electrolyte
4. Ionic conduction assumed by electrolyte
5. Cathode: aluminum foil

The positive plate is an etched aluminum foil covered with alumina which is the dielectric of the capacitor.

The negative plate is constituted by a second aluminum foil which serves as a current supply, and by electrolyte-impregnated papers layers.

The metal used for anode is a $\geq 99,98\%$ grade aluminum.

The dielectric has a thickness of $13 \text{ \AA} / V$.

The aluminum used for the cathode is a $\geq 98\%$ grade aluminum covered with a dielectric layer with a thickness of about 40 \AA .

2. DIAGRAM OF THE EQUIVALENT CIRCUIT

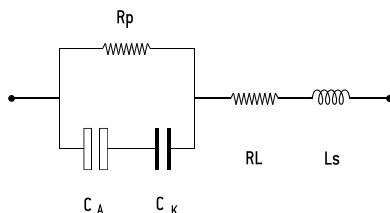

- C_A = Capacitance of the anode
- C_K = Capacitance of the cathode
- R_p = Parallel resistance due to the aluminum oxide film.
- R_L = Series resistance of connections, plates and impregnated spacer.
- L_s = Inductance of winding and connections.

A standard simplified diagram is.

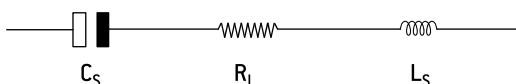

C_s is the series capacitance of both anode and cathode capacitances. Electrolytic aluminum capacitors are naturally polarized because of the insulating film on the anode. Given the very thin aluminum oxide layer, a reversed voltage should not exceed 1.5 V when there is energy supply.

Short duration reverse voltages can be absorbed by special construction, second anode replacing the former cathode.

3. CAPACITORS MARKING

3.1. ARTICLE CODE (ON EACH PACKAGING)

A followed by 6 figures number. First 3 positions are specific of the range. (Ex. A 745xxx for a FELSIC 85 BD)

140 FELSIC in bank	741 FELSIC 125 FRS BD (ex 731)
701 PRORELSIC 125	742 PRORELSIC 105 TFRS
703 PRORELSIC 125	743 PRORELSIC 105 TFRS
704 SNAPSIC	744 FELSIC 85 BC
705 SNAPSIC 105	FELSIC 85 LP
706 FELSIC HP BC – BD	745 FELSIC 85 BD
708 PRORELSIC 145	746 FELSIC 85 M BC
710 CUBISIC	747 FELSIC 85 M BD
711 PROMISIC 031	748 SICAL CO 42 - SICAL
712 CUBISIC LP	749 SICAL CO 42 - SICAL
713 SNAPSIC 105 LP	750 CUBISIC 125
714 SNAPSIC 4P	756 FELSIC 105 BC
715 SNAPSIC 105 4P	FELSIC 105 LP
716 SNAPSIC HV	757 FELSIC 105 BD
717 SNAPSIC HC	760 FELSIC 105 BC
718 SNAPSIC 125	761 FELSIC HC BD
721 RELSIC 033	762 FELSIC 105 TFRS BC
722 CI FRS	763 FELSIC 105 TFRS BD
723 CI FRS	764 FELSIC HV BC
728 FELSIC 039 (ex 72?)	765 FELSIC HV BD
FELSIC DI	775 VACSIC
738 FELSIC 037 (ex 73?)	774 VACSIC 150
740 FELSIC 125 FRS BC (ex 731)	776 ALSIC 20G
	ALSIC 145 20G

In FELSIC ranges, article code without first letter A, is printed on each capacitor.

a Figure 9 in fourth position shows a special product.

3.2. BATCH (ON EACH CAPACITOR).

3 figures or 6 figures

3.3. DATE (ON EACH CAPACITOR IF APPLICABLE)

4 figures (year-week)

4. ELECTRICAL CHARACTERISTICS

4.1. RATED CAPACITANCE C_R

The rated capacitance is defined at 100 Hz and at ambient temperature.

4.2. RATED VOLTAGE U_R

U_R is the maximum DC voltage which may be applied in continuous operation.

When applying a superimposed alternating voltage, the peak value of the resulting waveform should not exceed the rated voltage.

4.3. PEAK VOLTAGE U_p

U_p is the maximum repetitive voltage which can be applied within short periods.

Defined in CECC 30 300 and IEC 60 384-4:

1000 cycles of 30 s charge followed by a no load period of 5 min. 30 s with upper category temperature.

$$U_p \leq 1,15 U_R \quad (U_R \leq 315 \text{ V})$$

$$U_p \leq 1,10 U_R \quad (U_R > 315 \text{ V})$$

General technical data

4.4. DISSIPATION FACTOR TANδ

The dissipation or loss factor is defined by its tangent $\text{Tan}\delta$

$$\text{Tg}\delta = R_s C_s \omega$$

$$(\omega = 2\pi F)$$

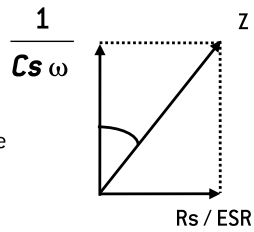

ESR Capacitor Equivalent Series Resistance

Cs Capacitor capacitance

F Frequency [100 Hz]

Z Capacitor impedance

4.5. EQUIVALENT SERIES RESISTANCE ESR

The relation between ESR and dissipation factor $\text{Tan}\delta$ is given in § 4.4.

4.6. IMPEDANCE Z - INDUCTANCE L

The impedance is given by:

$$Z = \sqrt{R^2 + \left[L\omega - \frac{1}{C\omega}\right]^2}$$

L inductance. Generally $L = 5$ to 20 nH

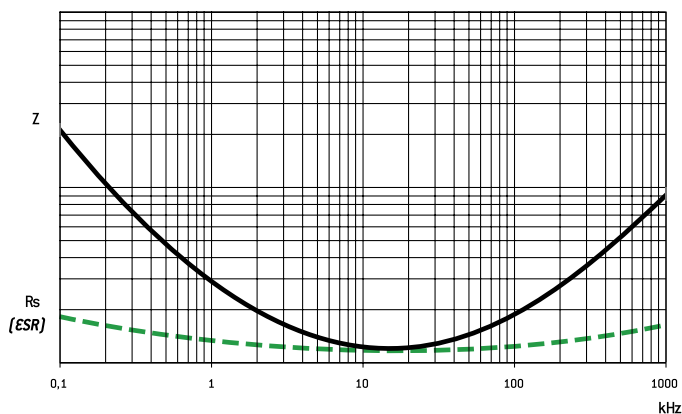

Z and ESR as function of frequency typically follows the chart:

4.7. PERMISSIBLE RIPPLE CURRENT (I r.m.s.) I~

The current is defined at the maximum climatic category and at 100 Hz. It is the root mean square value r.m.s. The value I_0 is the rated value for calculations of expected life up to $3 I_0$.

4.8. LEAKAGE CURRENT II

It is measured at 20°C after a 5 min. polarization under rated voltage.

For C_R in μF and U_R in V:

$I \leq 0,01 C_R U_R$ or $1 \mu\text{A}^*$

when $C_R U_R \leq 1000 \mu\text{C}$

$I \leq 0,006 C_R U_R + 4 \mu\text{A}$

when $C_R U_R > 1000 \mu\text{C}$

For $U_R > 350 \text{V}_{\text{DC}}$ it can be specified:

with $K = 4, 6$ or 8

or

$I \leq 0,3 (C_R U_R)^{0,7} + 4 \mu\text{A}$ (CECC 30 300)

* Whichever is the greater

4.9. CHARACTERISTICS

Versus temperature [typical values].

4.9.1. Capacitance drift

Versus temperature

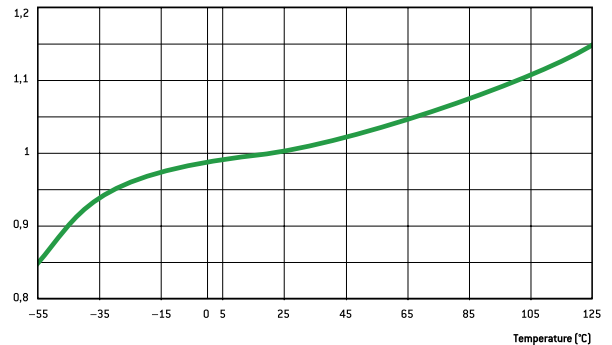

4.9.2. ESR and Z drifts at 100 Hz

Versus temperature

4.9.3 Leakage current drift

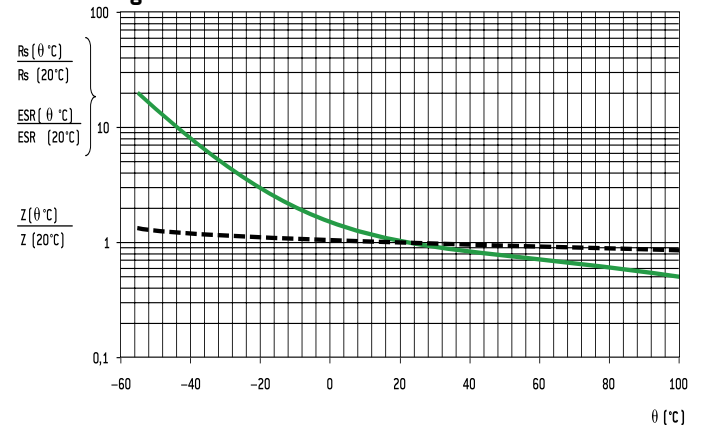

Versus temperature

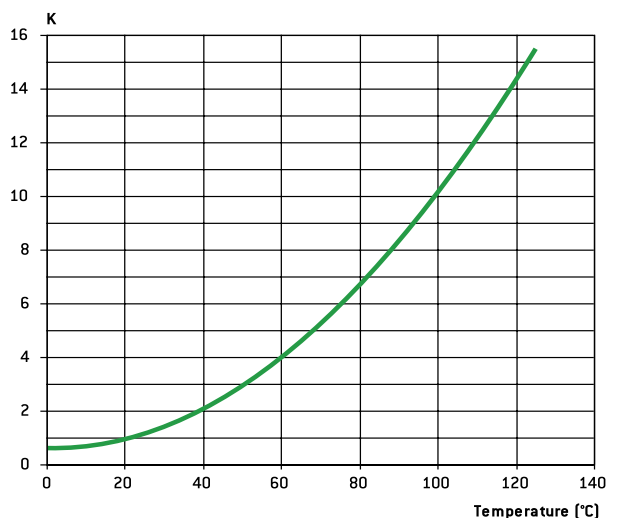

General technical data

5. SPECIFICATION TO APPLY

Electrolytic aluminum capacitors are defined in:

- NF and UTE French national standard
- CECC European specifications
- IEC international specifications

Quality insurance procedures are described in these specifications.

	French	European	International
Generic specification Fixed capacitors	NF C 83 100	CECC 30 000 EN 130 000	IEC 60 384 -1 QC 300 000
Sectional specification Electrolytic aluminum capacitors	NF C 83 110	CECC 30 300	IEC 60 384 - 4 C 300 300
Blank deta II specification - Electrolytic aluminum capacitors with non solid electrolyte.	UTE 83 110	CECC 30 301	IEC 60 384 - 4 -1 QC 300 301
Blank deta II specifications	CECC 30 301- 017 to CECC 30 301- 062 CO 31 to CO 55	CECC 30 301- 017 to CECC 30 301- 062 CECC 30 301- 802 to CECC 30 301- 811	

6. ENDURANCE TESTS / LIFE TIME

6.1. STANDARD ENDURANCE TEST

at max category temperature:

Temperature	Endurance test			
	Grade I - Long life			Grade II - General purpose
	10 000 h	5 000 h	2 000 h	1 000 h
125°C			•	
105°C		•	•	•
85°C	•	•	•	•

Standard endurance tests do not exceed 2000 hours at 125°C. However, present EXXELIA technologies concerning liquid electrolytes have led to endurance tests up to 5000 hours at 125°C (PRORELSIC 125 - FELSIC 125 RS) and even 20000 hours at 125°C (PRORELSIC 145 - ALSIC 145)

6.2. PERFORMANCE REQUIREMENTS ON STANDARD ENDURANCE TESTS.

Permissible capacitance drift $\Delta C/C$ (%)

Permissible increase factors on $\tan\delta$, ESR, Z and II initial values

U_R	Endurance test			
	Grade I			Grade II
	10 000 h	5 000 h	2 000 h	1 000 h
6,3 V			+15 -30	+25 -40
10 V - 35 V	+15 -20	± 15	± 15	± 30
40 V - 160 V	± 15	± 15	± 15	± 30
> 160 V	± 15	± 10	± 10	± 15

	Endurance test			
	Grade I			Grade II
	10 000 h	5 000 h	2 000 h	1 000 h
$\tan\delta$ or ESR [1]	1,5	1,3	1,3	1,5
Z [2]	3	2	2	3
II	Standard values			

[1] $\tan\delta$ or ESR: for initial value, take standard value.

[2] Z: for initial value, take specified value [see data sheet].

Specific requirements can be taken into consideration with regards to initial values of dissipation factor or equivalent series resistance and impedance.

6.3. FAILURE CRITERIA FOR ELECTROLYTIC CAPACITORS.

Failure criteria are defined in CECC 30 301

- Non measurable defaults leading to complete failure.
- Measurable defaults leading to adjustment losses of the load circuit (failure due to variations).

6.3.1. Non measurable defaults.

They might be summed up as:

- Open circuit
- Short circuit
- Operation of pressure relief device
- Severely damaged insulation
- Unusable terminations

6.3.2. Measurable defaults.

Variations exceeding the values given below characterize a default.

- Capacitance drift $\Delta C/C$ (%): 3 times the limit for standard endurance testing or 50 % (whichever is the smallest).
- $\tan\delta$ or ESR: 3 times standard max initial values.
- Z: 3 times standard max initial values.
- II: initial limit (under load conditions).

Specific requirements can be taken into consideration with regards to lower drifts.

6.4. INFLUENCE OF MAIN PARAMETER ON OPERATIONAL LIFE.

6.4.1. Temperature.

The capacitors operational life is highly dependent upon its internal temperature Θ_i and therefore upon the ambient temperature and the ripple current.

Knowing ESR and dissipated power values (§ 6.4.3.) one can figure out, the internal temperature rise and then determine the capacitors expected life.

With present high boiling point electrolytes (§ 8.6)

Θ_i max = 125 to 185°C depending on styles.

6.4.2. Ripple current.

The ripple current flowing through the capacitor increase the internal temperature through power dissipation.

Standards define the permissible current at 100 Hz and generally consider a temperature rise of 5 to 10°C of max category temperature.

Current waveforms and frequencies make it difficult to clearly determine the capacitors internal temperature rise, which defines the operationally life.

Experiments confirm following relationship:

$$\Theta_i = \Theta_a + (\Theta_c - \Theta_a) K$$

Where:

- Θ_i = Internal hot spot temperature
- Θ_a = Ambient temperature
- Θ_c = Case temperature
- K = Parameter depending upon case diameter and cooling
 - $\emptyset \geq 51$ k = $2 \pm 0,5$
 - $\emptyset < 51$ k = $1,5 \pm 0,5$ (air cooling - 0,2 m/s)

General technical data

r.m.s. value according to current waveform.

Function	Mean value	R.m.s. value	Function	Mean value	R.m.s. value	Function	Mean value	R.m.s. value
	$A (t_0/T)$	$A \sqrt{t_0/T}$		$A/2$	$A \sqrt{3}$		$2A/\pi$	$A/\sqrt{2}$
	$A (t_1/T)$	$A \sqrt{2t_1/3T}$		$2A/\pi (t_0/T)$	$A \sqrt{t_0/2T}$		$A/2$	$A/\sqrt{3}$
	$A/2 (t_0/T)$	$A \sqrt{t_0/3T}$		$A/2 (t_0/T)$	$A \sqrt{t_0/3T}$		0	A

6.4.3. Dissipated power versus case dimension

For calculations of ripple currents, considering an internal temperature rise of 10°C

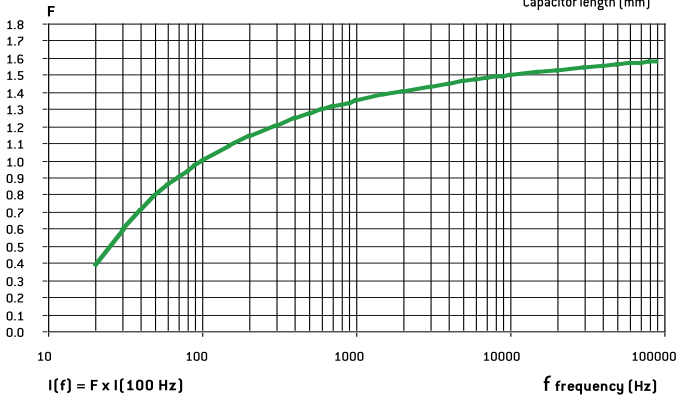
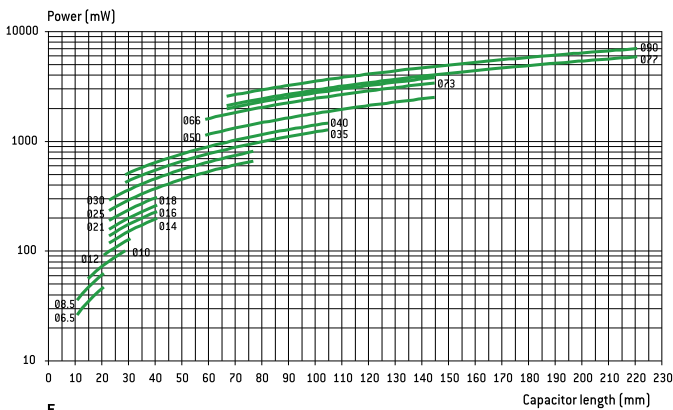

$P = ESR \cdot I^2$

P = Dissipated power (mW)

($\Theta_i - \Theta_a = 10^\circ\text{C}$)

ESR: Equivalent series resistance (100 Hz 20°C)

I: Ripple current (r.m.s. value at 100 Hz)

For different frequencies from 100 Hz, I must be multiplied by the factor F, according to above chart.:

6.4.4. Thermal resistance Rth and air cooling

Rth is static thermal resistance (without cooling) between capacitor central hot spot and ambient temperature measured at a distance of one capacitor diameter

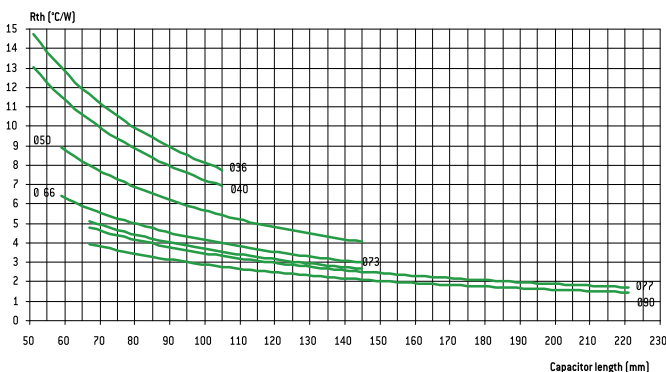

Forced or not cooling air can lead to a significant decrease of these values.

Consequently, r.m.s. ripple current can be increased as a function of air cooling speed:

Ø mm (inches)	≤ 0,5 m/s	1 m/s	2 m/s	3 m/s	≥ 4 m/s
66 - 90	1~	1,1~	1,2~	1,25~	1,3~
36 - 51	1~	1,2~	1,4~	1,45~	1,5~

This parameter shall be applied to one capacitor alone.

For capacitors in bank, ambient temperature must be strictly equal around all capacitors.

6.4.5. Quality guaranty

We guarantee products manufactured during 2 years from the data of shipment against defaults of material and assembly.

This guaranty can be involved by the buyer only if our products are used within normal conditions, always according to the state of the art and taking in account storage conditions.

The equipment design should take into consideration possible failures of our capacitors and related effects in order to avoid them.

Guaranty is not applicable for damages occurred by surge voltage, irregular use, polarity inversion or maintenance default.

Guaranty is exclusively limited to the replacement of individual defective capacitors within the terms of delivery. This rule applied to all cases and particularly to any further consequence of failures.

6.4.6. Reliability

Failure rate:

$$FR = \frac{\text{Number of components tested} \times \text{test duration}}{\text{Number of failures}}$$

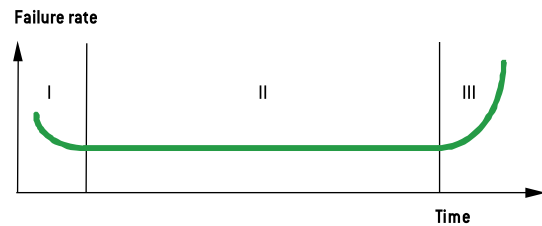

Failure rate is measured in FIT (failure in time = 10^{-9} / hour).

The failure rate is set up during the life time of the capacitor (phase II)

I. Early failure phase (generally excluded during ageing process).

II. Operational life time of the capacitors

III. End of life

General technical data

Mean time between failures MTBF = 1/FR mesured in years

Range	Failure rate for a failure percentage not exceeding 1% with a confidence level of 60 %
FELSIC 85 >350 V FELSIC HC > 350 V SNAPSIC - SNAPSIC HC > 350 V SNAPSIC 4P > 350 V PROMISIC 031 Ø = 6,5 SICAL CO 42 - SICAL > 350 V	50 FIT - (MTBF = 2280)
FELSIC 037 - 039 FELSIC 85 ≤ 350 V FELSIC HC ≤ 350 V CUBISIC CI FRS SNAPSIC 105 - SNAPSIC 105 4P SNAPSIC 105 LP - SNAPSIC HV SNAPSIC - SNAPSIC 4P ≤ 350 V SNAPSIC HC ≤ 350 V ALSIC IR - ALSIC 145 - ALSIC HV - VACSIC 150 - VACSIC SICAL CO 42 - SICAL ≤ 350 V PRORELSIC 125 Ø = 6,5 RELSIC 033 PROMISIC 031 Ø > 6,5	25 FIT - (MTBF = 4560)
FELSIC 125 FRS - SNAPSIC 125 FELSIC HV - FELSIC 105	10 FIT - (MTBF = 11410)
PRORELSIC 125 Ø > 6,5 PRORELSIC 145	5 FIT - (MTBF = 22820)

Multiplying factor of FR with voltage and temperature

Factor	Temperature [°C]							
	≤ 40	50	60	70	85	105 (1)	125 (1)	145 (1)
Factor	1	1,5	2,3	3,4	6,3	14	32	72

(1) Only for permitted capacitors

Factor	Percentage of rated voltage (2)		
	100 %	80 %	50 %
Factor	1	0,8	0,5

(2) This voltage has to be constant

Environ- ment	Without vibration		Ground with vibrations or mobile			
	Ground, fix Controlled air	Ground, fix	PRORELSIC SNAPSIC 20 g FELSIC 20 g	FELSIC 10 g PROMISIC SICAL Ø ≤14	CI FRS - SNAPSIC RELSIC SICAL Ø >14	ALSIC
Factor	1	2	2	4	6	12

7. MANUFACTURING FLOW CHART

Process controls

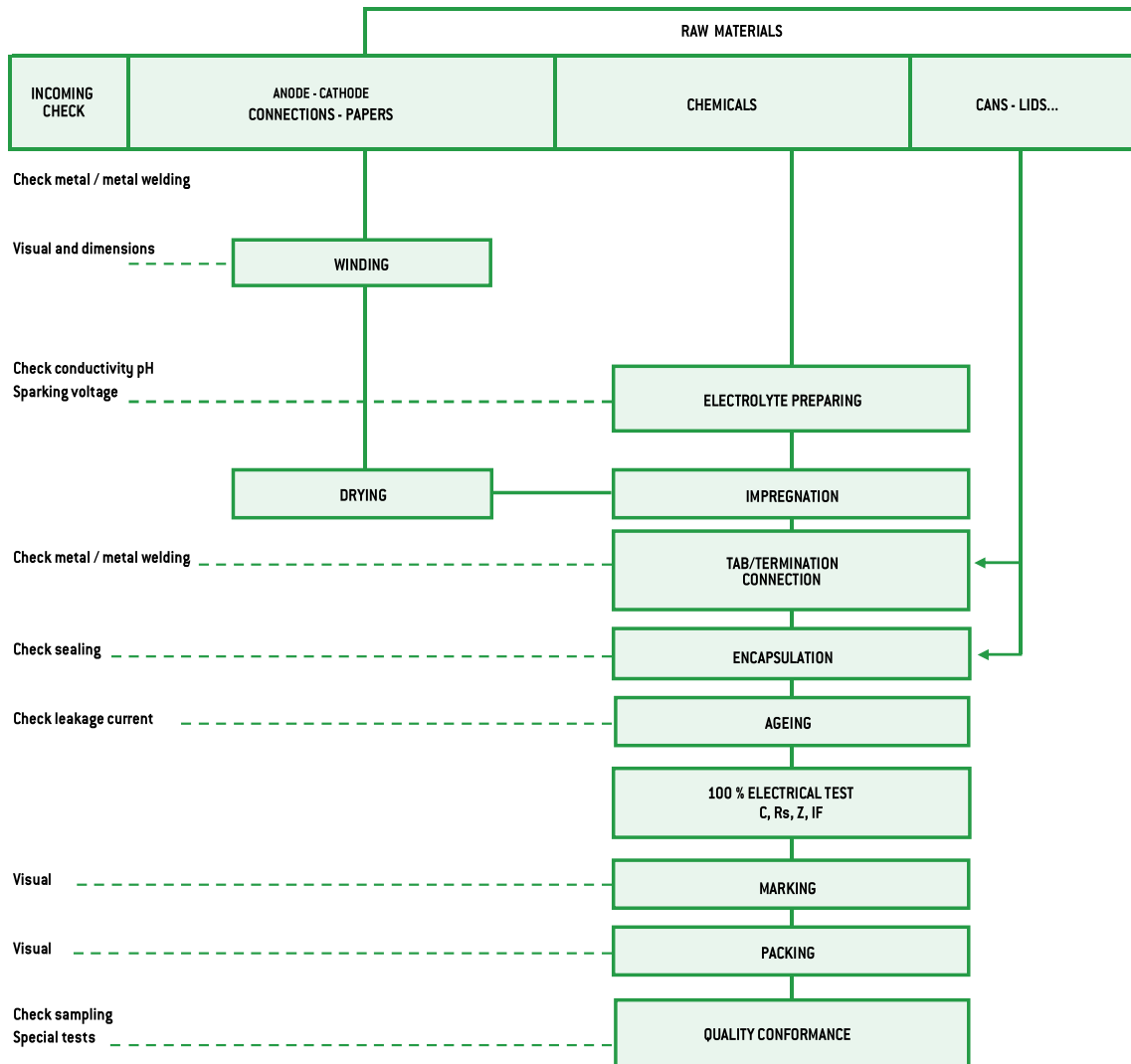

General technical data

8. INFORMATION ON APPLICATION

8.1. CLEANING SOLVENTS

Use aliphatic alcohols, such as denatured ethyl alcohol, isopropanol, or butylacetate, or else alkaline diluted solutions. Avoid incompatible solvents (halogenous for example).

8.2. SHELF LIFE

There is no electrical characteristics variation for long periods of storage except leakage current which can increase.

It is caused by chemical reactions between the dielectric alumina and the electrolyte. These reactions are reversible when switched on. Capacitors can generally be stored at temperature between -5° and $+50^{\circ}\text{C}$ without reforming for the following periods of time:

- For $U_R \leq 100\text{ V}$, storage time: 5 years (up to 10 years under specific conditions)
- For $100\text{ V} < U_R \leq 360\text{ V}$ storage time: 3 years
- For $360\text{ V} < U_R < 500\text{ V}$ storage time: 1 year
- For $U_R \leq 500\text{ V}$, storage time: 6 months

Generally when these periods are overstepped, one hour at rated voltage causes the decrease of leakage current under the specified limits. An other way to avoid this leakage current increase problem is to always limit available power through capacitor during first seconds or minutes after storage or transport, according to the following chart:

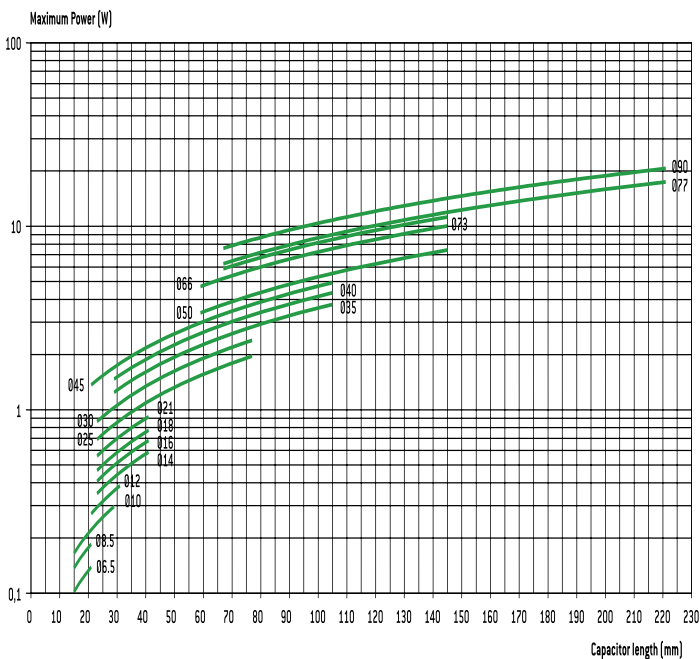

8.3. LOW PRESSURE RESISTANCE

EXXELIA capacitors can be used with ambient low pressure decreasing up to 10 mbar (altitude 28000 m – 92000 feet).

8.4. MOUNTING SCREW TERMINALS CAPACITORS (FELSIC)

Capacitors may be used vertically (terminals on top) or horizontally. When used horizontally, the following position in relation to the safety vent, is recommended:

Mounting capacitors in series may be used for operating voltage exceeding U_R . See FELSIC in bank.

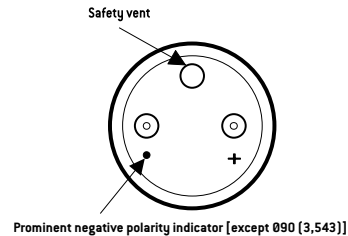

8.5. MOUNTING SOLDER TYPE CAPACITORS.

They may be used in any position. During mounting, avoid applying excessive force to capacitor pins or wires. There is a risk of damaging internal connections.

After soldering and for the same reasons, do not try to move the capacitor's body.

8.6. ELECTROLYTES: SAFETY RULES.

Electrolytes used in EXXELIA capacitors are manufactured by EXXELIA. Main solvents are generally γ butyrolactone and ethylene glycol, very stable high boiling point solvents. Ionic conductive salts in electrolyte induce a very weak acidity (pH 5 to 7).

8.7. ENVIRONMENT.

In aluminium capacitors with liquid electrolyte there is no component showing a pollution risk, in small amounts, of air or water. EXXELIA is always involved in this security field particularly in using chemicals for electrolyte, without well-known risks.

- Dimethylformamide (DMF) dangerous solvent forbidden in several uses is completely excluded by EXXELIA, since 1990.
- There is no halogen compound such as chlorofluorocarbon (CFC or FCKW in German) or polychlorobiphenyl (PCBPyralene) or pentabromodiphenylether or octabromodiphenylether.

There is neither benzene, toluene or phenyl compound nor explosive such as picric acid, nor asbestos in plastic covers. All the capacitors made by EXXELIA since 1991, can be scrapped or used in raw materials recycling processes without special care in compliance with Community rules.

EXXELIA aluminium capacitors with non-solid electrolyte are particularly suitable for different kinds of environment taking in account severity increasing laws.

European directives 2003/11/EC, 2002/96/EC (WEEE) and 2002/95/EC (RoHS) applies to all EXXELIA capacitors including every solder type, manufactured with pure tin coated pins or wires, since at least January 2006.

Mounting and insulating parts

STUD FIXING: FELSIC BD

Steel nut, spring washer and insulating washer are delivered loosely with the capacitor.

STANDARD MOUNTING WITH:

Insulating washer and steel nut

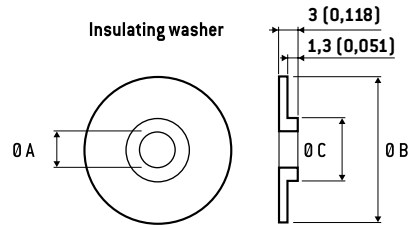
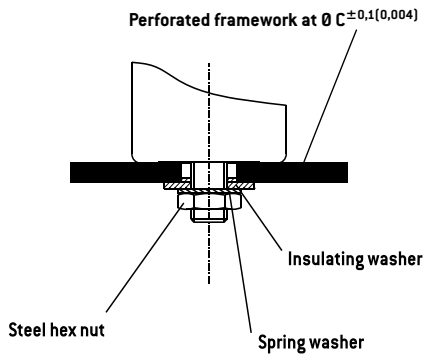

Ø Capacitor	DIMENSIONS in mm (inches)				Code
	M	Ø A	Ø B	Ø C	
36	8	8,4	25	18,5	A 691060
51 - 77	12	12,5	30	21,5	A 691061
90	12	12,5	35	21,5	A 691062

Insulating plastic nut with or without insulating washer

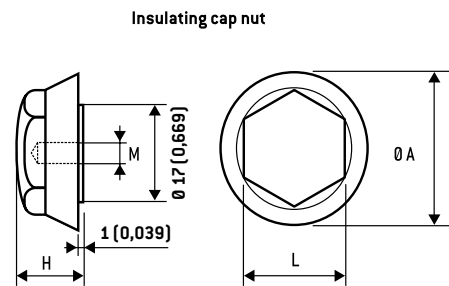
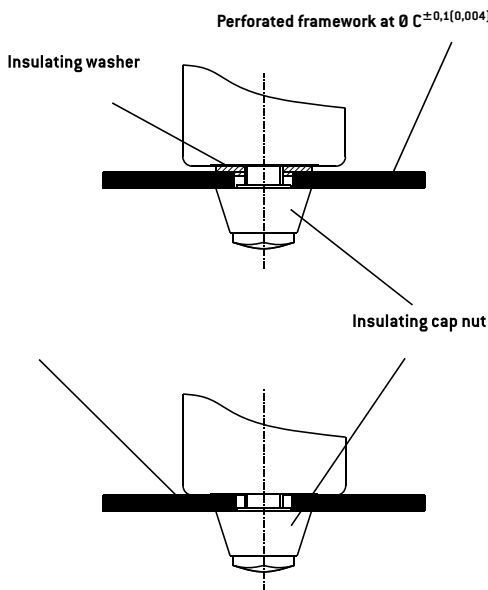

M	Ø A	H	L	Max. torque	Code
8 [0,315]	25 [0,984]	15 [0,591]	17 [0,669]	3 Nm	A 691070
12 [0,472]	30 [1,181]	20 [0,787]	19 [0,748]	7 Nm	A 691071

Ring - clip mounting: FELSIC LP

Ring clips shall be ordered separately.

Tightening screws and nuts are supplied loosely.

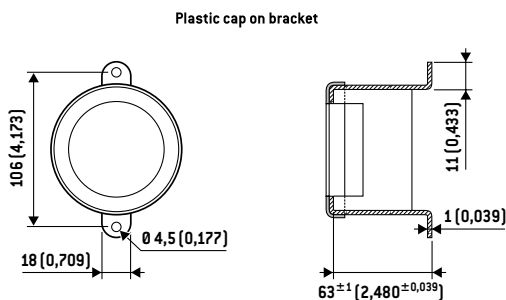

FELSIC 85 LP FELSIC 105 LP	Code
Metal bracket	A691055
Plastic cap	A691065

General technical data

Ring - clip mounting: FELSIC BC

Ring clips shall be ordered separately.

Tightening screws and nuts are supplied loosely.

FELSIC BC - Metal ring-clips

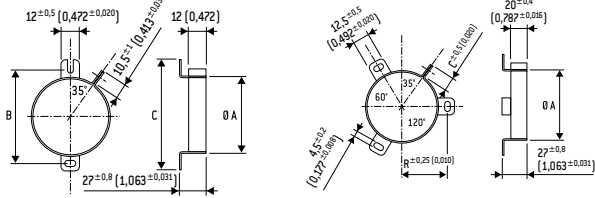

Ø A Cap.	B	C	Code	Ø A Cap.	B	C	Code
36 (1,417)	54 (2,126)	63 (2,480)	A 691901	51 (2,008)	33,5 (1,319)	11,8 (0,465)	A 691905
				66 (2,598)	39 (1,535)	10,5 (0,413)	A 691913
				73 (2,874)	44 (1,732)	10,5 (0,413)	A 691914
				77 (3,031)	44,5 (1,752)	10,5 (0,413)	A 691907
				90 (3,543)	53,3 (2,098)	11,8 (0,465)	A 691915

Stirrup mounting: CUBISIC LP

Stirrups shall be ordered separately.

Tightening screws and nuts are supplied loosely

Salt mist endurance of screws and mounting accessories:
minimum 96 h (IEC 600 68-2-11)

CUBISIC /CUBISIC LP - Metal bracket

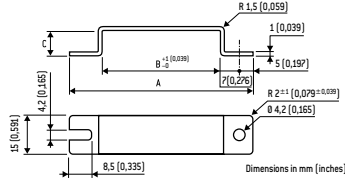

Ø A Cap.	A	B	C	Code
45x12 (1,772x0,472)	69 (2,717)	45 (1,772)	10 (0,394)	A 691057
35x16 (1,378x0,630)	59 (2,323)	35 (1,378)	14 (0,551)	A 691059

PACKAGING

1. PACKAGING AND WEIGHT UNITS.

1.1. Capacitor with screw terminals

Can DIMENSIONS in mm (inches)				Unit weight *
Ø	H			(g)
36 (1,417)	47 (1,850)	52 (2,047)	53 (2,087)	70
36 (1,417)	60 (2,362)			79
36 (1,417)	80 (3,150)	81 (3,189)		100
36 (1,417)	104 (4,094)	105 (4,134)		120
51 (2,008)	47 (1,850)			80
51 (2,008)	62 (2,441)	63 (2,480)		105
51 (2,008)	81 (3,189)	82 (3,228)		190
51 (2,008)	104 (4,094)	105 (4,134)		260
51 (2,008)	112 (4,409)			270
51 (2,008)	144 (5,669)			370
66 (2,598)	104 (4,094)	105 (4,134)		430
66 (2,598)	112 (4,409)			460
73 (2,874)	104 (4,094)	112 (4,409)		600
73 (2,874)	144 (5,669)			680
77 (3,031)	104 (4,094)	105 (4,134)		620
77 (3,031)	144 (5,669)	145 (5,709)		860
77 (3,031)	200 (7,874)			1300
77 (3,031)	220 (7,874)	221 (8,701)		1400
90 (3,543)	67 (2,638)			600
90 (3,543)	144 (5,669)	145 (5,709)		1400
90 (3,543)	200 (7,874)			1800

* Unit weight = typical values

Possible variations of = ± 25 % according to different voltage and capacitance.

1.2. Radial solder types

Can dimensions mm (inches)			ALSIC	SNAP-SIC	Can dimensions			ALSIC	SNAP-SIC
Ø	H	Weight* (g)			Ø	H	Weight* (g)		
10 (0,394)	16 (0,630)	1,8	-		35 (1,378)	30 (1,181)	-	50	
12,5 (0,492)	21 (0,827)	4,5	-		35 (1,378)	40 (1,575)	-	50	
12,5 (0,492)	24 (0,945)	5	-		35 (1,378)	45 (1,772)	-	52	
					35 (1,378)	50 (1,969)	-	60	
16 (0,630)	25 (0,984)	8,2	-		35 (1,378)	75 (2,953)	-	95	
					35 (1,378)	100 (3,937)	-	125	
22 (0,866)	25 (0,984)	-	15		40 (1,575)	40 (1,575)	-	65	
22 (0,866)	30 (1,181)	-	17		40 (1,575)	50 (1,969)	-	100	
22 (0,866)	40 (1,575)	-	18		40 (1,575)	75 (2,953)	-	130	
					40 (1,575)	100 (3,937)	-	170	
25 (0,984)	25 (0,984)	-	17		45 (1,772)	21 (0,827)	-	50	
25 (0,984)	30 (1,181)	-	20		45 (1,772)	(0,984)	-	60	
25 (0,984)	35 (1,378)	-	22		45 (1,772)	30 (1,181)	-	73	
25 (0,984)	40 (1,575)	-	25		45 (1,772)	35 (1,378)	-	85	
25 (0,984)	45 (1,772)	-	28		45 (1,772)	45 (1,772)	-	110	
25 (0,984)	50 (1,969)	-	30		45 (1,772)	75 (2,953)	-	180	
					45 (1,772)	100 (3,937)	-	240	
30 (1,181)	25 (0,984)	-	28						
30 (1,181)	30 (1,181)	-	30						
30 (1,181)	35 (1,378)	-	30						
30 (1,181)	40 (1,575)	-	40						
30 (1,181)	45 (1,772)	-	45						
30 (1,181)	50 (1,969)	-	50						

Can DIMENSIONS in mm (inches)			CUBISIC
I	L	H	weight (g)
35 (1,378)	35 (1,378)	16 (0,630)	30
35 (1,378)	50 (1,969)	16 (0,630)	40
45 (1,772)	35 (1,378)	12 (0,472)	30
45 (1,772)	50 (1,969)	12 (0,472)	45
45 (1,772)	75 (2,953)	12 (0,472)	60

* Unit weight = typical values

Possible variations of = ± 25 % according to different voltage and capacitance.

1.3. Axial types

Can DIMENSIONS in mm (inches)		PRORELSIC RELSIC	PRORELSIC PROMISIC	SICAL CO 42 SICAL
Ø	H	Unit weight * (g)	Unit weight * (g)	Unit weight * (g)
6,5 (0,256)	15 (0,591)	-	1,6	-
6,5 (0,256)	19 (0,748)	-	1,8	1,8
8,5 (0,335)	19 (0,748)	-	2,3	2,3
10 (0,394)	19 (0,748)	-	2,8	2,8
10 (0,394)	25 (0,984)	-	3,5	3,5
10 (0,394)	28 (1,102)	-	3,8	-
12 (0,472)	25 (0,984)	-	5	-
12 (0,472)	30 (1,181)	-	5,4	5,4
14 (0,551)	30 (1,181)	-	6,9	6,9
14 (0,551)	41 (1,614)	-	9,5	-
(0,630)	30 (1,181)	7,7	-	7,7
18 (0,709)	35 (1,378)	13,6	-	-
18 (0,709)	40 (1,575)	15,3	-	15,3
21 (0,827)	40 (1,575)	19,5	-	19,5
25 (0,984)	40 (1,575)	28	-	28
25 (0,984)	50 (1,969)	35	-	35
25 (0,984)	75 (2,953)	56	-	56

* Unit weight = typical values

Possible variations of = ± 25 % according to different voltage and capacitance.

General technical data

2. PACKAGING ON TAPE

2.1. Axial types

Dimensions and tolerance in accordance with IEC 60 286-

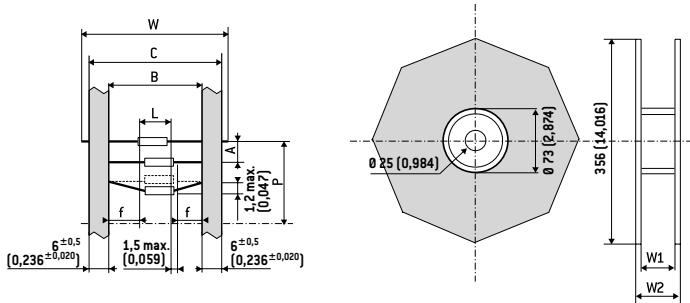

DIMENSIONS in mm (inches)									
D	L max.	B	A	P	C max.	W ₁	W ₂ max.	W	n ⁽²⁾
6,5 (0,256)	20 (0,787)	73 ± 1,5 (2,874 ± 0,059)	10 ± 1,5 (0,394 ± 0,059)	± 2 (0,079)	87,5 (3,445)	93 (3,661)	106 (3,661)	85 ± 1,5 (3,346 ± 0,059)	1000 (39,370)
8,5 (0,335) ⁽¹⁾									750 (29,528)
10 (0,394) ⁽¹⁾	32 (1,260)	73 ± 1,5 (2,874 ± 0,059)	15 ± 1,5 (0,591 ± 0,059)	± 3 (0,118)	87,5 (3,445)	93 (3,661)	106 (3,661)	85 ± 1,5 (3,346 ± 0,059)	400 (15,748)
12 (0,472) ⁽¹⁾									400 (15,748)
14 (0,551) ⁽¹⁾									200 (7,874)

(1) On tape only on request

(2) n = number of capacitors per reel.

White positive tape f : > 20 mm (0,787 inches)

P: 10 space