

COAXIAL RESONATORS

Thanks to its high know-how in ceramic material manufacturing, **EXXELIA TEMEX** has developed its own coaxial resonator product line. These products are the poles of filter, oscillator and duplexer functions for Telecom, Military & Space, Industrial and Wireless applications.

Coaxial resonators are designed to use the size-reducing effect of high dielectric constant materials in microwave functions such as VCOs (Voltage Controlled Oscillators), CROs (Coaxial Resonator Oscillators) and filters. Their use allows designers to get more compact devices.



I. Basic Properties

Resonance effect origins

The most commonly used mode in many applications is the TEM (Transverse Electro-Magnetic) mode. Such mode has neither electric nor magnetic field in the direction of propagation. They are contained primarily within the metallized ceramic.

Let's consider a line in which a signal is sent through "IN" and received in "OUT". When a coaxial resonator is connected, this one allows or blocks (whether it is $\lambda/2$ or $\lambda/4$ configurations) microwave energy corresponding to its resonant frequency (see Figure 1).

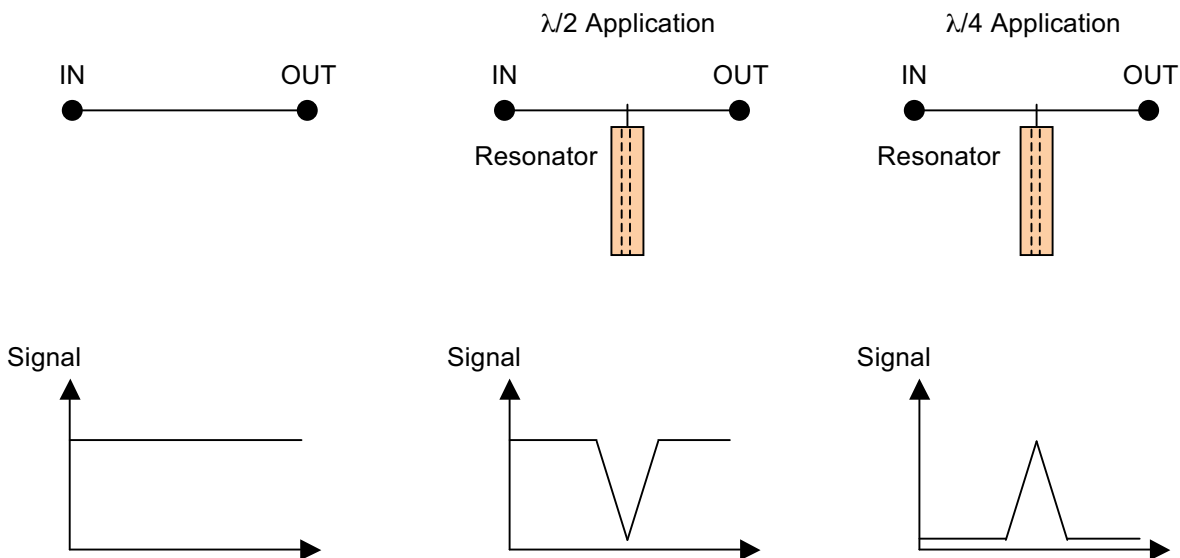

EXXELIA TEMEX reserves the right to modify herein specifications and information at any time when necessary to provide optimum performance and cost.

COAXIAL RESONATORS

Resonant frequency: f

The frequency is governed by the length of the coaxial resonator. This length is usually close to a quarter or half wavelength of the required frequency. Resonators are then defined as either quarter or half wavelength type.

Quarter wavelength resonators have only one end metallized to "short-circuit" the center conductor to the outer conductor, whereas both ends are non-metallized on half wavelength types. Frequency is given by:

- 1/2 applications :

$$f = \frac{300}{2L\sqrt{\epsilon_r}}$$

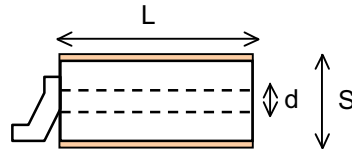

- 1/4 applications :

$$f = \frac{300}{4L\sqrt{\epsilon_r}}$$

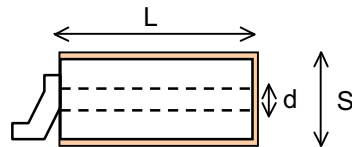

where f is the resonant frequency (GHz), L the resonator length (mm) and ϵ_r the dielectric constant.

Useful simplified formulas are given in below table to determine the resonator length.

	1/4 application	1/2 application
$\epsilon_r = 21$	$L = \frac{16.37}{f}$	$L = \frac{32.73}{f}$
$\epsilon_r = 38.5$	$L = \frac{12.09}{f}$	$L = \frac{24.17}{f}$
$\epsilon_r = 90$	$L = \frac{7.91}{f}$	$L = \frac{15.81}{f}$

Impedance: Z_0

The coaxial resonator impedance is directly linked to the section, the inner hole diameter and the dielectric constant of the material. An equivalent circuit is given by a common RLC circuit.

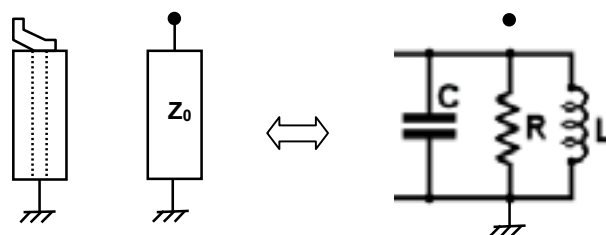

COAXIAL RESONATORS

For a 1/4 coaxial resonator, having a nominal frequency f (MHz), a section S (mm), an inner hole diameter d (mm) and a dielectric constant ϵ_r , the lumped elements are given by:

$$L = \frac{2Z_0}{\pi^2 f} \quad C = \frac{1}{8Z_0 f} \quad R = \frac{4Z_0 Q}{\pi}$$

with

$$\left\{ \begin{array}{l} Z_0 = \frac{60}{\sqrt{\epsilon_r}} \cdot \ln\left(1.079 \cdot \frac{S}{d}\right) \\ Q = 60 \cdot \frac{S\sqrt{f}}{25.4} \end{array} \right.$$

Quality factor: Q

What is essentially required by designers is the lowest bandwidth at 3dB giving a more selective frequency. This performance is directly given by the Q factor which is essentially determined by the metallization. A thick film silver coating is then realized for excellent Q. Let's note that a low loss dielectric material does not influence at the first order the Q factor.

$$Q = 60 \cdot \frac{S\sqrt{f}}{25,4}$$

II. User Guide

How to order "Commercial Models"

CRS	06	T	Q	1500	F	S	1	E	Rohs
Type Coaxial resonator	Size See table	Material V (ϵ_r 21) T (ϵ_r 38.5) N (ϵ_r 90)	Application Q : $\lambda/4$ H : $\lambda/2$	Frequency (MHz) See range in table	Frequency tolerance F = $\pm 1\%$ D = $\pm 0.5\%$ 5 = ± 5 MHz 1 = ± 1 MHz	Metallization S : Silver	Connection 0 : none 1 : one 2 : wire 4 : ribbon	T&R E : T&R Blank : none	Rohs compliant

How to order "Flight Models"

CRS	06	T	Q	1500	F	S	0	TRFxxx	Rohs
Type Coaxial resonator	Size See table	Material V (ϵ_r 21) T (ϵ_r 38.5) N (ϵ_r 90)	Application Q : $\lambda/4$ H : $\lambda/2$	Frequency (MHz) See range in table	Frequency tolerance F = $\pm 1\%$ D = $\pm 0.5\%$	Metallization S : Silver	Connection 0 : none	Hi-Rel	Rohs compliant

Note: flight models are delivered with tab separately

EXXELIA TEMEX reserves the right to modify herein specifications and information at any time when necessary to provide optimum performance and cost.

COAXIAL RESONATORS

Materials and applications

Our portfolio is designed to offer the highest degree of freedom to electronic engineers. Several dielectric constants are available (21/38.5/90) allowing the best trade-off between impedance, Q factor and resonant frequency.

Operating temperature range: -40°C / +85°C

Frequency range and general characteristics

Quarter wavelength applications

Applications	Dielectric constant	t _f (ppm/°C)	Section (mm)	Without tab Frequency range (MHz)	With tab Frequency range (MHz)
1/4	21	0 ± 15	2	2135 - 6000	2135 - 6000
			3	1335 - 6000	1335 - 4190
			4	870 - 5520	870 - 4190
			6	650 - 3310	650 - 3140
			8	915 - 3000	915 - 2870
			10	915 - 3000	N/A
	38.5	0 ± 15	2	1575 - 6000	1575 - 4470
			3	1005 - 4560	1005 - 3090
			4	660 - 4140	660 - 3090
			6	490 - 2430	490 - 2320
			8	690 - 3000	690 - 2120
			10	690 - 3000	N/A
	90	0 ± 15	2	1040 - 3970	1040 - 2920
			3	650 - 2940	650 - 2020
			4	410 - 2650	410 - 2020
			6	305 - 1590	305 - 1520
			8	410 - 1800	410 - 1380
			10	445 - 1800	N/A
			12	330 - 1500	330 - 940

Others frequencies on request

Half wavelength applications

Applications	Dielectric constant	t _f (ppm/°C)	Section (mm)	Without tab Frequency range (MHz)	With tab Frequency range (MHz)
1/2	21	0 ± 15	2	4305 - 12000	4305 - 12000
			3	2730 - 12000	2730 - 8390
			4	1735 - 11000	1735 - 8390
			6	1365 - 6625	1365 - 6290
			8	1890 - 3000	1890 - 3000
			10	1890 - 3000	N/A
	38.5	0 ± 15	2	3100 - 12000	3100 - 8950
			3	2050 - 9130	2050 - 6190
			4	1315 - 8280	1315 - 6190
			6	1000 - 4965	1000 - 4640
			8	1420 - 3000	1420 - 3000
			10	1420 - 3000	N/A
	90	0 ± 15	2	2100 - 7940	2100 - 5850
			3	1315 - 5880	1315 - 4050
			4	840 - 5300	840 - 4050
			6	630 - 3180	630 - 3040
			8	840 - 3000	840 - 2770
			10	895 - 3000	N/A
			12	685 - 2500	685 - 1880

Others frequencies on request

COAXIAL RESONATORS

Q factor

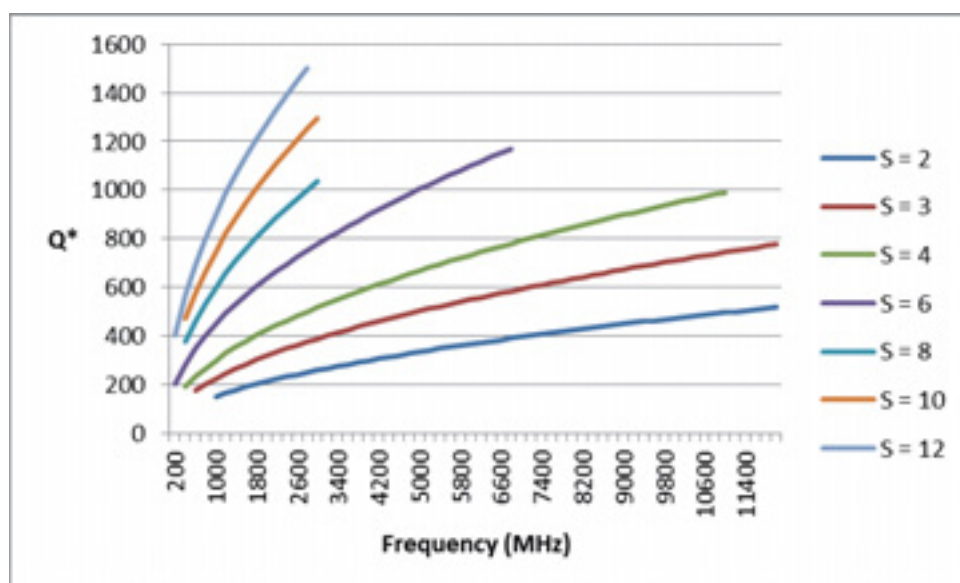

* Typical values

Dimensions and impedance

Section (± 0.2 mm)	Inner hole diameter (± 0.1 mm)	Impedance (ohm)			Temex Ceramics Reference
		$\epsilon_r = 21$	$\epsilon_r = 38.5$	$\epsilon_r = 90$	
2	0.65	15.7	11.6	7.6	CRS02
	0.80	13.0	9.6	6.3	CRS22
3	0.95	15.6	11.9	7.6	CRS03
4	1.20	16.8	12.4	8.1	CRS14
	1.50	13.8	10.2	6.7	CRS04
6	2.00	10.1	7.4	4.9	CRS24
	2.00	15.4	11.4	7.4	CRS06
	2.20	14.1	10.4	6.8	CRS16
	2.40	13.0	9.6	6.3	CRS26
8	2.50 *	12.5	9.2	6.0	CRS36
8	2.80	14.7	10.9	7.1	CRS08
10	3.50 *	14.7	10.9	7.1	CRS10
12	3.50	17.1	12.6	8.3	CRS12
	4.00 *	15.4	11.4	7.4	CRS412

* Connection not available

Connection dimensions

Section	2	3	4	6	8	10	12
L1 (mm) +/- 0.1	0.65	0.70	0.80	1.20	1.50	N/A	2.00
L2 (mm) +/- 0.2	1.00	1.30	1.30	1.80	1.80	N/A	2.50
e (mm) +/- 0.1	0.40	0.50	0.60	0.80	0.80	N/A	1.00

