

# NON MAGNETIC, SAPPHIRE DIELECTRIC TRIMMER CAPACITORS

## SAPPHIRE DIELECTRIC TRIMMER CAPACITORS, RoHS COMPLIANT

### Description

Sapphire dielectric

**Non Magnetic structure**

Rated voltage 500 VDC to 1500 VDC

Low magnetic signature, less than  $10^{-12}$  Tesla

Low temperature coefficient

Very stable over time

High Q factor

Multi-turn, high resolution

Self-locking constant torque drive mechanism

Silver and chromate finish

**ROHS compliant**

**Maximum Soldering Temperature 260°C, 3 s Max**



### Applications

Magnetic Resonance Imaging

Nuclear Magnetic Resonance

Medical Applications

Non magnetic probes

## I. Electrical specifications

P/N	AT 57290 ROHS	AT 57250 ROHS	TG 091 ROHS	TG 092 ROHS
Capacitance range	0.8 to 8.0 pF >16 turns	1.0 to 13 pF > 8 turns	0.5 to 8.0 pF > 28 turns	0.5 to 10 pF > 28 turns
Working Voltage	500 VDC	1500 VDC	1500 VDC	1000 VDC
Test Voltage	1000 VDC	2250 VDC	2500 VDC	1600 VDC
Working Temp. range	-55°C to + 125°C			
Temp. Coefficient	350+/-75 ppm/°C	350+/-75 ppm/°C	350+/-75 ppm/°C	350+/-75 ppm/°C
Q factor	>3000@100 MHz	>1500@100 MHz	>2500@100 MHz	>2000@100 MHz
Insulation Resistance	>10 <sup>4</sup> MΩ			

Capacitance change is linear versus rotation of mobile rotor.

EXXELIA TEMEX reserves the right to modify herein specifications and information at any time when necessary to provide optimum performance and cost.

# NON MAGNETIC, SAPPHIRE DIELECTRIC TRIMMER CAPACITORS

## SAPPHIRE DIELECTRIC TRIMMER CAPACITORS, RoHS COMPLIANT

### II. Mechanical and general specifications

P/N	AT 57290 ROHS TG 091 ROHS TG 092 ROHS	AT 57250 ROHS
Rotating torque	10 to 100 g.cm	50 to 500 g.cm
Max torque on rotor stop	150 g.cm	700 g.cm
Rotational life	> 400 revolutions	> 400 revolutions
Vibrations	60g, 10-2000 Hz	60g, 10-200 Hz
Shocks	100g, 6 ms	100g, 6 ms

### IV. Models and dimensions in mm

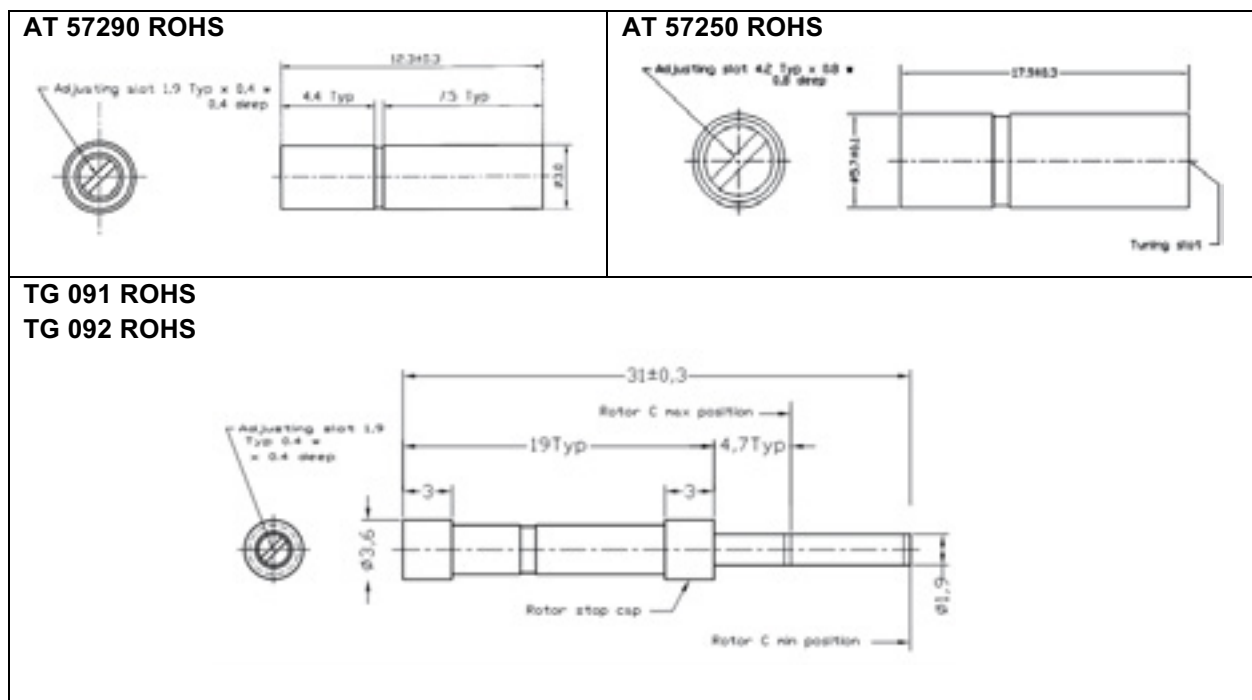

**NOTA:** AT 57290 ROHS and AT 57250 ROHS can be delivered with extended shaft upon request.

### V. Soldering

**Hand soldering:** Use a temperature controlled 40 watts iron set at 260°C maximum. The solder joint should be made on 3 seconds or less.

EXXELIA TEMEX reserves the right to modify herein specifications and information at any time when necessary to provide optimum performance and cost.

# NON MAGNETIC, SAPPHIRE DIELECTRIC TRIMMER CAPACITORS

## SAPPHIRE DIELECTRIC TRIMMER CAPACITORS, RoHS COMPLIANT

### VI. Recommendations for cleaning

Delivered without sealing cap, these Trimmer Capacitors have to be installed after circuit board have been cleaned.

### VII. Packaging

Parts are delivered in bulk.

### VIII. How to order

Non Magnetic High Voltage Sapphire Dielectric trimmer capacitors

Reference	RoHS
-----------	------

Examples

AT 57290	ROHS
AT 57250	ROHS

### IX. Tuning tool

Recommended Tuning Tool reference is **AT 8777**

Improper screwdriver size will cause internal thread damage.

### X. Adjusting

The maximum torque on rotor stop value should not be exceeded or damage to capacitor may result.

Always use the recommended tuning tool.