

KPF



Highlights

- Self-healing property
- High DV / DT
- Low ESR
- Low loss polypropylene dielectric
- Reference standard-IEC 61071
- Flame retardant UL94 - V0, ROHS compliant

Construction

Extended foil electrodes with Metallized polypropylene dielectric internal series connection

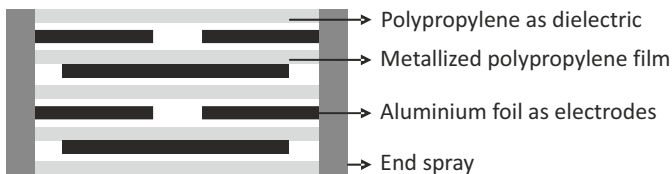

Applications

These capacitors are used in high voltage, high current and high pulse applications such as:

- IGBT protection circuits
- Snubber networks
- Energy conversion and control in power electronics
- Protection circuits in SMPS

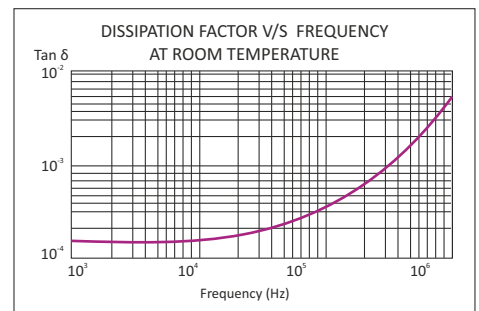
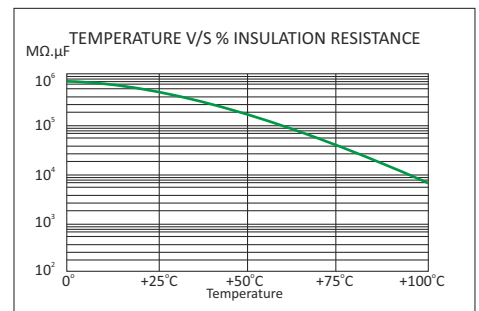
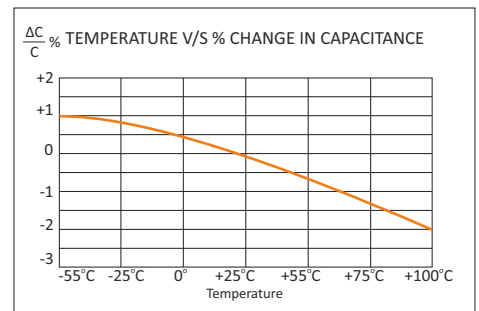
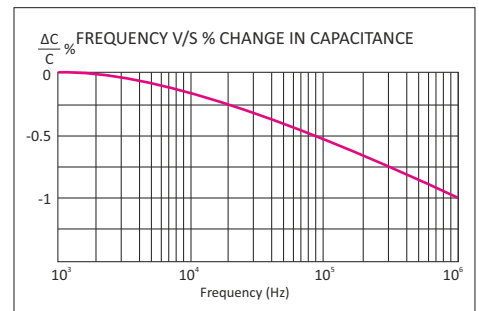
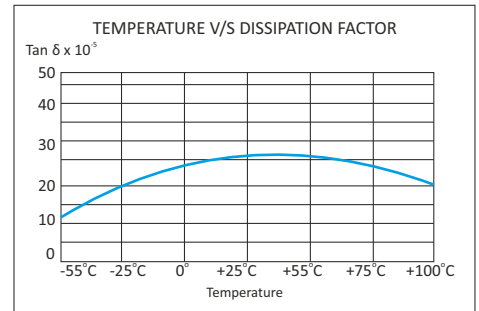

KPF

Technical Specifications

Physical Characteristics

▪ Dielectric material	Polypropylene film.
▪ Electrode material	Aluminum foil and metallized polypropylene film
▪ Winding construction	Extended foil electrodes with metallized polypropylene dielectric internal series connection
▪ Enclosure	Preformed UL 94 V-0 plastic case with thermosetting resin-fill

Electrical Characteristics

▪ Capacitance range	0.1 MFD to 3.3 MFD
▪ Capacity tolerance	±5%(J), ±10%(K)
▪ Rated voltage VDC	1000, 1250, 1500, 2000
▪ Rated voltage VAC	480, 550, 630, 700
▪ Test voltage between terminals	1.6 x rated voltage VDC for 2 seconds
▪ Test voltage terminal to case	3KVAC at 50Hz for 60 seconds
▪ Dissipation factor (Tan d)	≤0.0005 at 1 KHz and 25°C
▪ Temperature range	-40°C to +85°C
▪ Insulation resistance at 25°C & at a test voltage of 500 VDC applied for 1 minute	C ≤ 0.33 MFD ≥100,000MΩ C > 0.33 MFD ≥30,000MΩ

Marking on Capacitors

Each capacitor will have the following information printed on it, sequentially:

- The Company's symbol  followed by the words ALCON
- The capacitor grade viz KPF
- The capacitance value MFD
- The rated voltage VDC
- Capacity tolerance and manufacturing code
- Part number on non-standard capacitors

KPF

Standard Capacitor Values

Working Voltage 1000 VDC (480 VAC)

Rated Capacitance MFD	Case Code	DV/DT V/ μ Sec	I Peak Amps	Irms Max at 100KHz & 70°C Amps	Typical ESR at 100KHz m Ω	Ordering Code*
0.100	K2	1200	120.00	5.60	11.20	SI00U101000AF0K2_ _ _ _ K01
0.150	K2	1200	180.00	5.70	10.80	SI00U151000AF0K2_ _ _ _ K01
0.220	K3	1200	264.00	6.80	10.40	SI00U221000AF0K3_ _ _ _ K01
0.220	B1, C1	1200	264.00	18.20	4.20	SI00U221000AF_ _ _ _ _ K01
0.270	B1, C1	1000	270.00	18.70	4.00	SI00U271000AF_ _ _ _ _ K01
0.330	B1, C1	1000	330.00	19.70	3.70	SI00U331000AF_ _ _ _ _ K01
0.390	B1, C1	1000	390.00	20.60	3.70	SI00U391000AF_ _ _ _ _ K01
0.470	B1, C1	1000	470.00	21.10	3.50	SI00U471000AF_ _ _ _ _ K01
0.560	B1	900	504.00	21.30	3.50	SI00U561000AF0B1_ _ _ _ K01
0.680	B1	900	612.00	21.30	3.50	SI00U681000AF0B1_ _ _ _ K01
0.750	E1	900	675.00	25.60	3.20	SI00U751000AF0E1_ _ _ _ K01
0.820	E1	900	738.00	26.00	3.00	SI00U821000AF0E1_ _ _ _ K01
1.000	E1	900	900.00	26.00	3.00	SI00U011000AF0E1_ _ _ _ K01
1.200	B3	900	1080.00	26.00	2.50	SI01U201000AF0B3_ _ _ _ K01
1.500	B3	900	1350.00	26.00	2.50	SI01U501000AF0B3_ _ _ _ K01
1.750	E2	800	1400.00	28.00	2.50	SI01U751000AF0E2_ _ _ _ K01
2.000	E2	800	1600.00	28.20	2.50	SI00U021000AF0E2_ _ _ _ K01
2.200	E2	700	1540.00	28.50	2.40	SI02U201000AF0E2_ _ _ _ K01
2.500	E3	600	1500.00	29.00	2.20	SI02U501000AF0E3_ _ _ _ K01
3.000	C2	600	1800.00	30.00	2.00	SI00U031000AF0C2_ _ _ _ K01
3.300	C2	600	1980.00	30.00	2.00	SI03U301000AF0C2_ _ _ _ K01

Working Voltage 1250 VDC (550VAC)

Rated Capacitance MFD	Case Code	DV/DT V/ μ Sec	I Peak Amps	Irms Max at 100KHz & 70°C Amps	Typical ESR at 100KHz m Ω	Ordering Code*
0.100	K2	1400	140.00	5.60	11.20	SI00U101250AF0K2_ _ _ _ K01
0.150	K2	1400	210.00	5.70	10.80	SI00U151250AF0K2_ _ _ _ K01
0.220	K3	1400	308.00	6.80	10.40	SI00U221250AF0K3_ _ _ _ K01
0.220	B1, C1	1400	308.00	18.20	4.20	SI00U221250AF_ _ _ _ _ K01
0.270	B1, C1	1200	324.00	18.70	4.00	SI00U271250AF_ _ _ _ _ K01
0.330	B1, C1	1200	396.00	19.70	3.70	SI00U331250AF_ _ _ _ _ K01
0.390	B1, C1	1200	468.00	20.60	3.70	SI00U391250AF_ _ _ _ _ K01
0.470	B1	1200	564.00	21.10	3.50	SI00U471250AF0B1_ _ _ _ K01
0.560	E1	1100	616.00	21.30	3.50	SI00U561250AF0E1_ _ _ _ K01
0.680	E1	1100	748.00	21.30	3.50	SI00U681250AF0E1_ _ _ _ K01
0.750	E1	1100	825.00	25.60	3.20	SI00U751250AF0E1_ _ _ _ K01
0.820	B2	1100	902.00	26.00	3.00	SI00U821250AF0B2_ _ _ _ K01
1.000	B2	1100	1100.00	26.00	3.00	SI00U011250AF0B2_ _ _ _ K01
1.200	E2	800	960.00	26.00	2.50	SI01U201250AF0E2_ _ _ _ K01
1.500	E2	800	1200.00	26.00	2.50	SI01U501250AF0E2_ _ _ _ K01
1.750	E3	800	1400.00	28.00	2.50	SI01U751250AF0E3_ _ _ _ K01
2.000	E3	800	1600.00	28.20	2.50	SI00U021250AF0E3_ _ _ _ K01
2.200	C2	800	1760.00	28.50	2.40	SI02U201250AF0C2_ _ _ _ K01
2.500	C2	800	2000.00	29.00	2.20	SI02U501250AF0C2_ _ _ _ K01

Custom-designed capacitors are available on request
Refer to "Capacitor Drawing" on page 18 to 23

KPF

Standard Capacitor Values

Working Voltage 1500VDC (630VAC)

Rated Capacitance MFD	Case Code	DV/DT V/ μ Sec	I Peak Amps	Irms Max at 100KHz & 70°C Amps	Typical ESR at 100KHz m Ω	Ordering Code*
0.100	K2	1600	160.00	5.60	11.20	SI00U101500AF0K2_ _ _ _ K01
0.150	K2	1600	240.00	5.70	10.80	SI00U151500AF0K2_ _ _ _ K01
0.220	B1,C1	1600	352.00	18.20	4.20	SI00U221500AF_ _ _ _ _ K01
0.270	B1,C1	1400	378.00	18.70	4.00	SI00U271500AF_ _ _ _ _ K01
0.330	B1,C1	1400	462.00	19.70	3.70	SI00U331500AF_ _ _ _ _ K01
0.390	E1	1400	546.00	20.60	3.70	SI00U391500AF0E1_ _ _ _ K01
0.470	E1	1400	658.00	21.10	3.50	SI00U471500AF0E1_ _ _ _ K01
0.560	E2	1300	728.00	21.30	3.50	SI00U561500AF0E2_ _ _ _ K01
0.680	E2	1300	884.00	21.30	3.50	SI00U681500AF0E2_ _ _ _ K01
0.750	E2	1300	975.00	25.60	3.20	SI00U751500AF0E2_ _ _ _ K01
0.820	E2	1300	1066.00	26.00	3.00	SI00U821500AF0E2_ _ _ _ K01
1.000	E2	1300	1300.00	26.00	3.00	SI000011250AF0B2_ _ _ _ K01
1.200	E2	1300	1560.00	26.00	2.50	SI01U201500AF0E2_ _ _ _ K01
1.500	E3	1300	1950.00	26.00	2.50	SI01U501500AF0E3_ _ _ _ K01
1.750	E3	1000	1750.00	28.00	2.50	SI01U751500AF0E3_ _ _ _ K01
2.000	C2	1000	2000.00	28.20	2.50	SI000021500AF0C2_ _ _ _ K01

Working Voltage 2000VDC (700VAC)

Rated Capacitance MFD	Case Code	DV/DT V/ μ Sec	I Peak Amps	Irms Max at 100KHz & 70°C Amps	Typical ESR at 100KHz m Ω	Ordering Code*
0.100	B1	1900	190.00	13.20	8.40	SI00U102000AF0B1_ _ _ _ K01
0.150	B1	1900	285.00	15.11	7.00	SI00U152000AF0B1_ _ _ _ K01
0.220	E1	1900	418.00	19.80	4.50	SI00U222000AF0E1_ _ _ _ K01
0.270	E1	1900	513.00	21.70	4.30	SI00U272000AF0E1_ _ _ _ K01
0.330	B2	1700	561.00	22.20	4.10	SI00U332000AF0B2_ _ _ _ K01
0.390	B3	1700	663.00	22.50	4.00	SI00U392000AF0B3_ _ _ _ K01
0.470	B3	1700	799.00	22.50	4.00	SI00U472000AF0B3_ _ _ _ K01
0.560	E2	1600	896.00	22.70	3.80	SI00U562000AF0E2_ _ _ _ K01
0.680	E3	1600	1088.00	22.80	3.70	SI00U682000AF0E3_ _ _ _ K01
0.750	E3	1500	1125.00	23.20	3.40	SI00U752000AF0E3_ _ _ _ K01
0.820	C2	1500	1230.00	23.20	3.30	SI00U822000AF0C2_ _ _ _ K01
1.000	C2	1500	1500.00	23.30	3.20	SI000012000AF0C2_ _ _ _ K01

Custom-designed capacitors are available on request
Refer to "Capacitor Drawing" on page 18 to 23

KPF

Capacitor Drawings and Terminal Styles

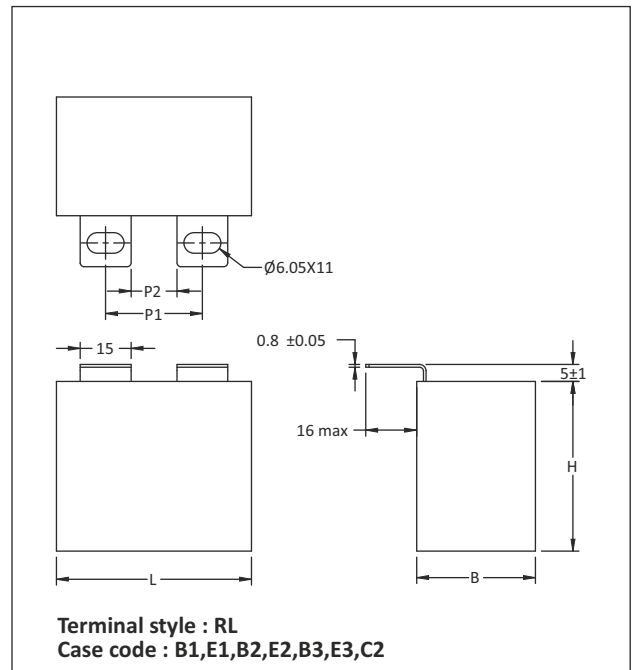
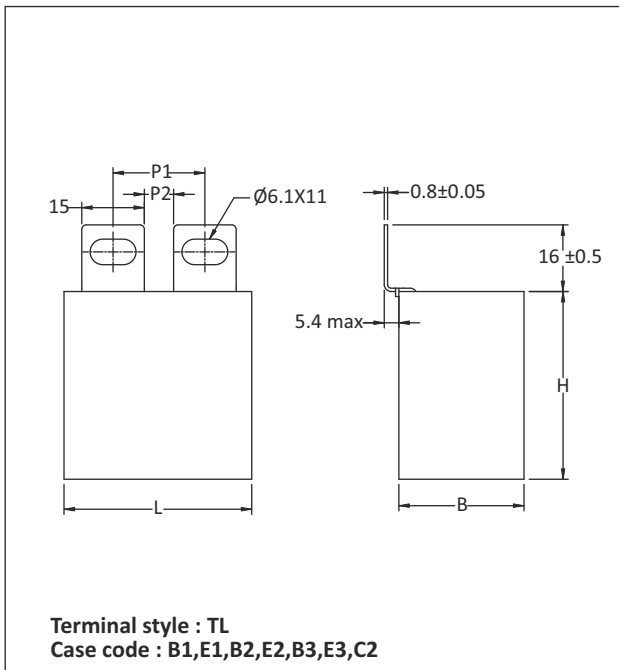
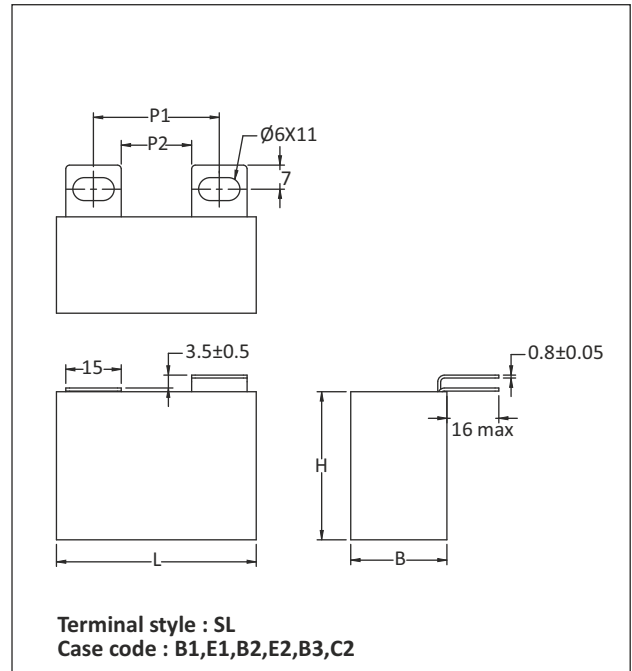
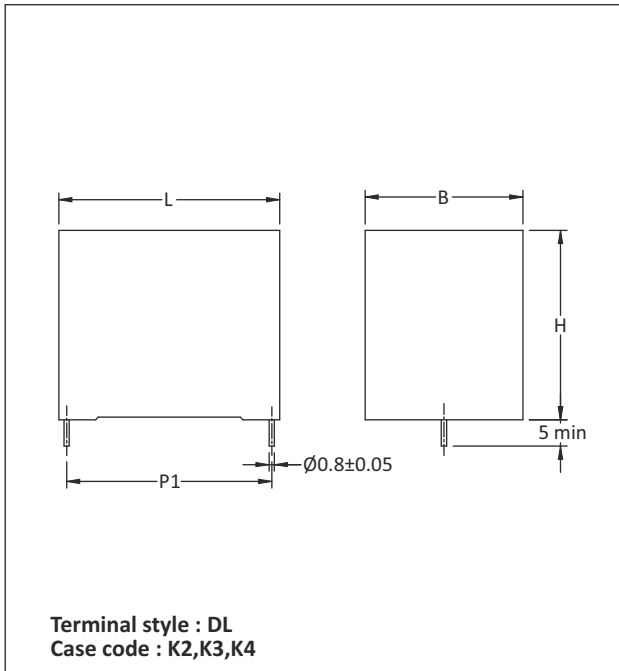

Dimensions in mm

For details see Case Code table on page 16 & 17

KPF

Capacitor Drawings and Terminal Styles

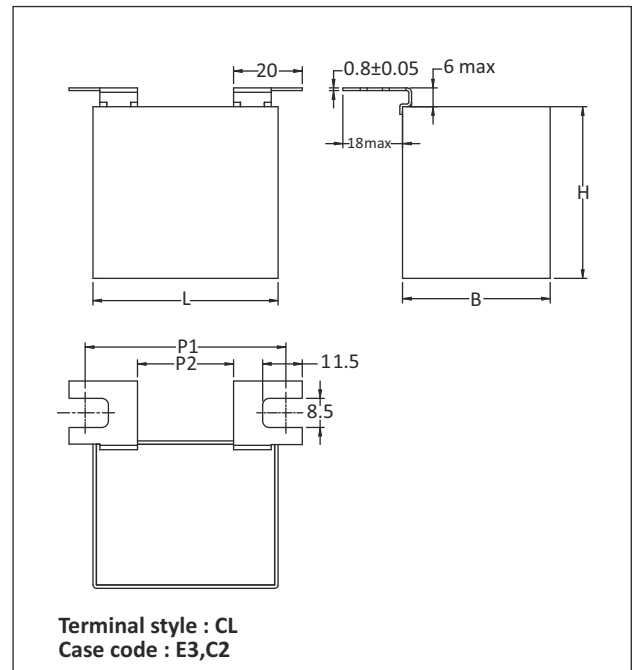
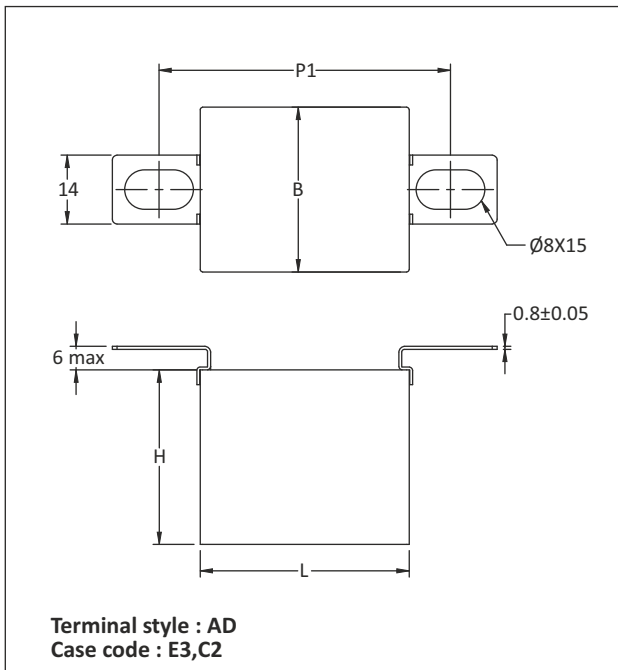
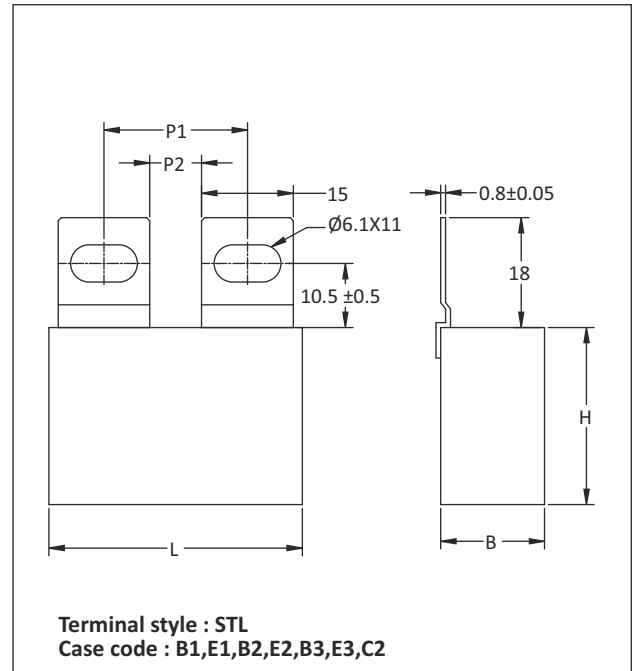
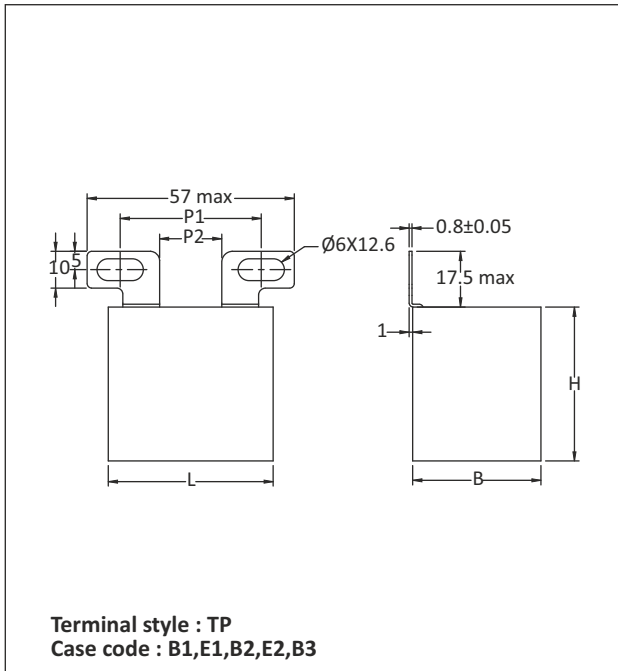

Dimensions in mm

For details see Case Code table on page 16 & 17

KPF

Capacitor Drawings and Terminal Styles

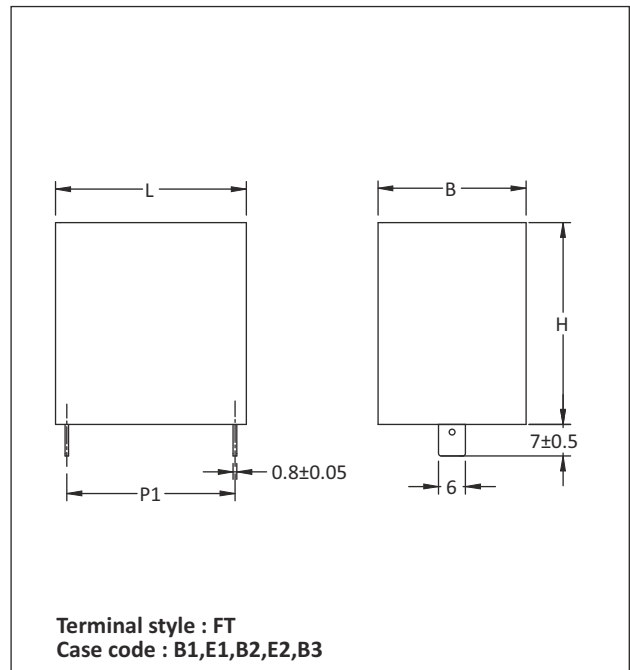
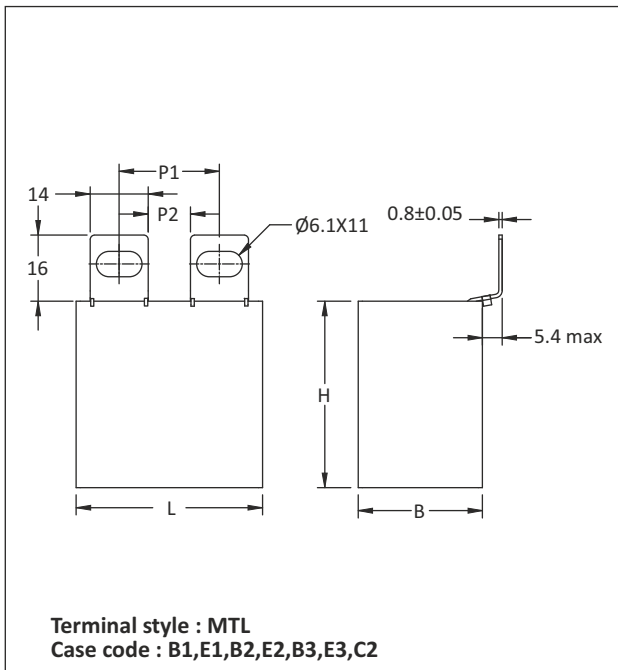
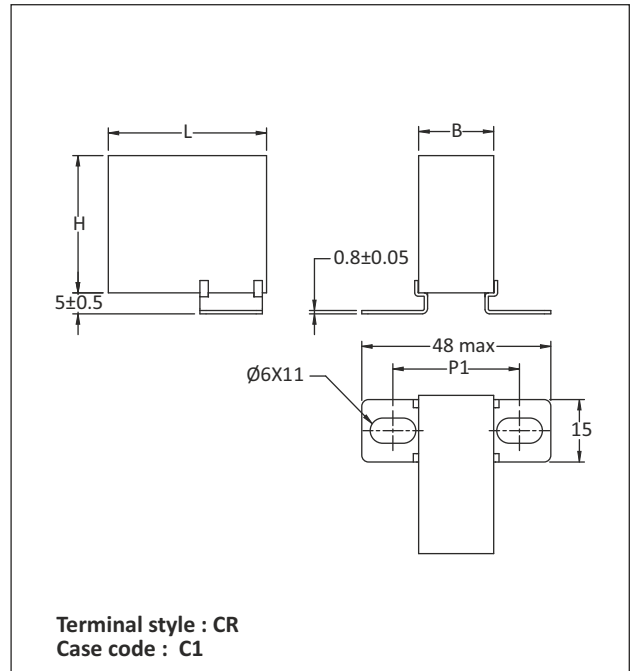
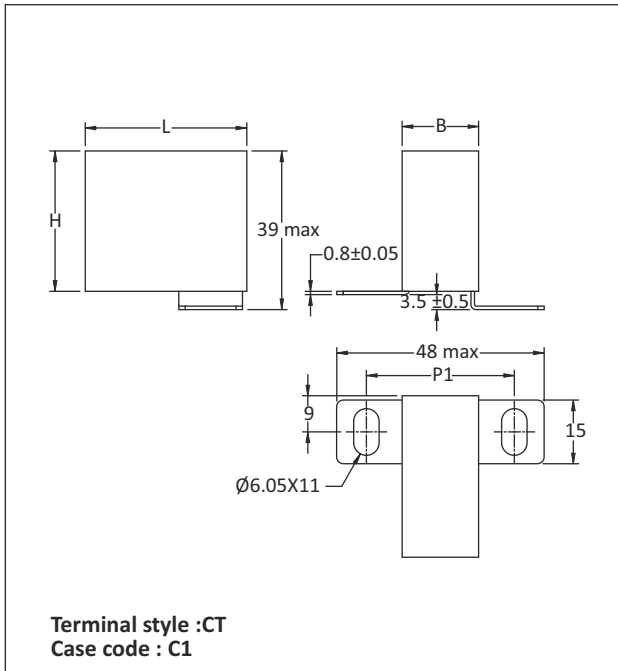

Dimensions in mm

For details see Case Code table on page 16 & 17

KPF

Capacitor Drawings and Terminal Styles

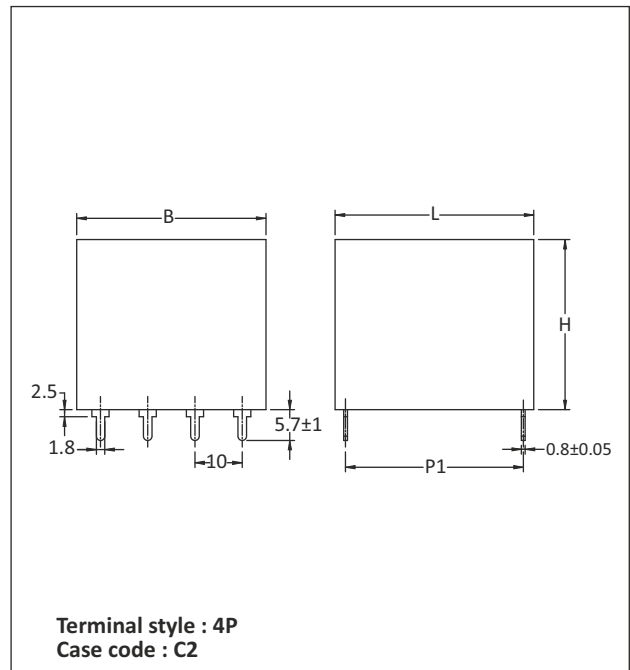
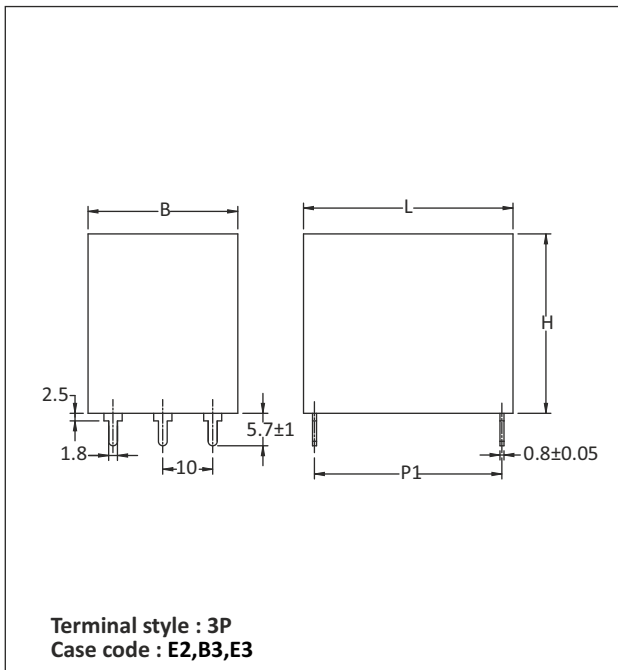
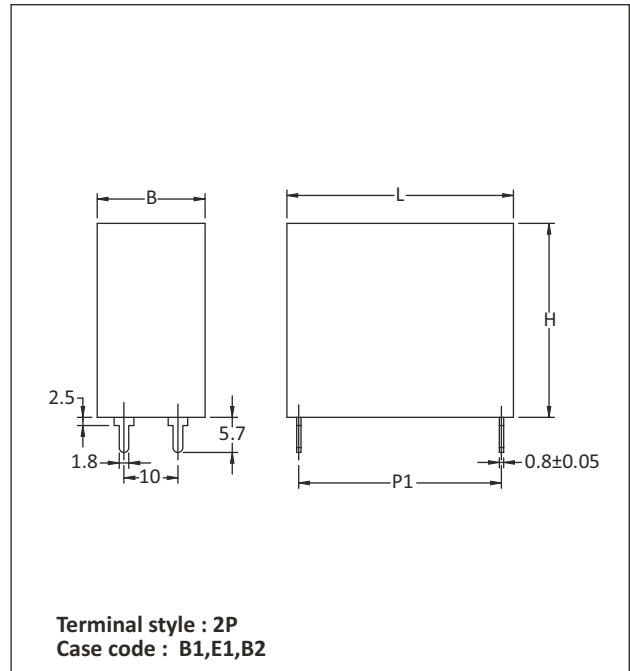
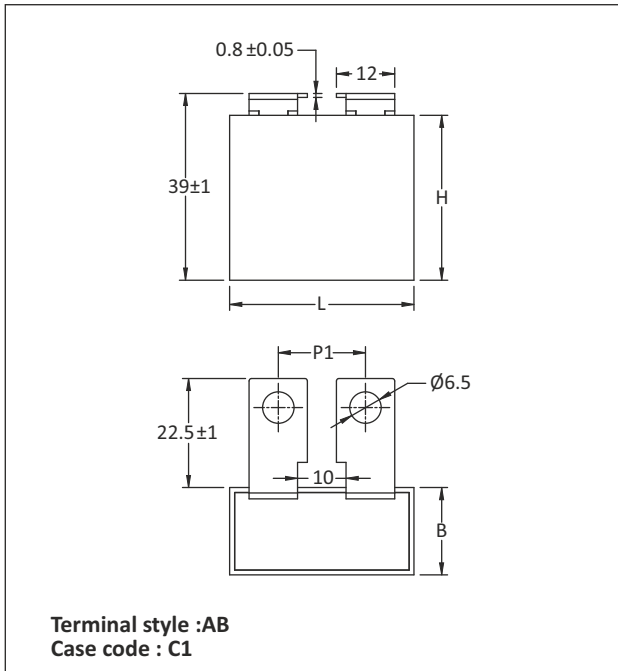

Dimensions in mm

For details see Case Code table on page 16 & 17

KPF

Capacitor Drawings and Terminal Styles

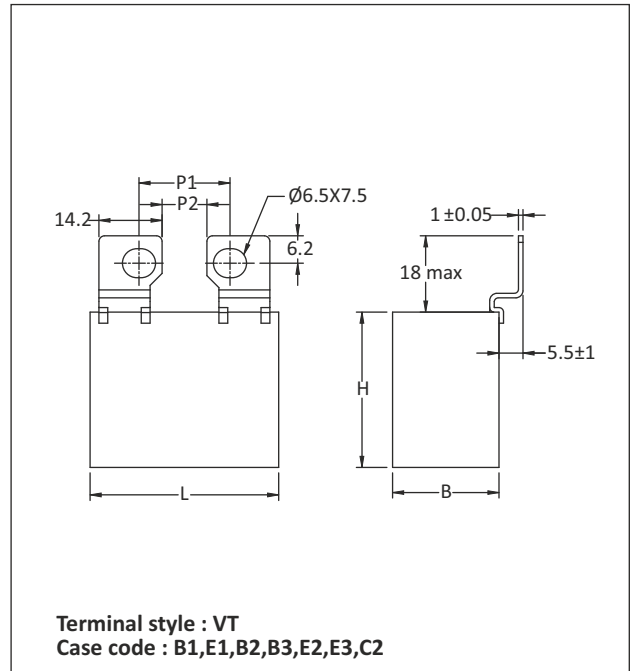
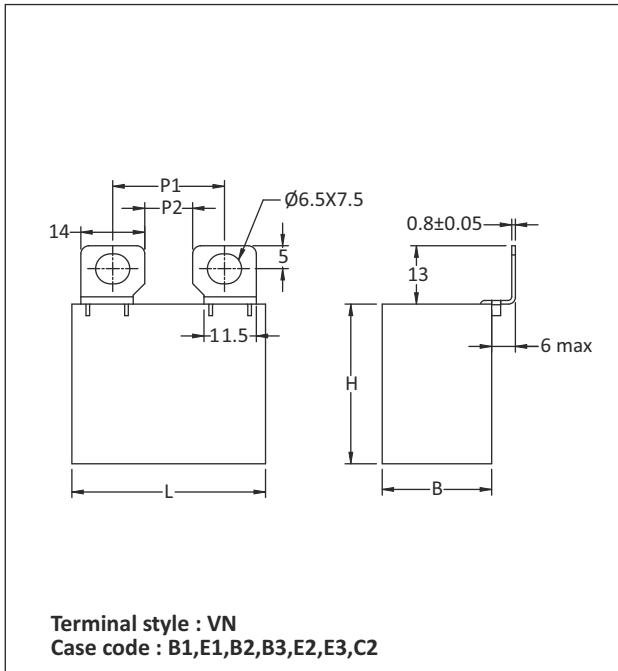
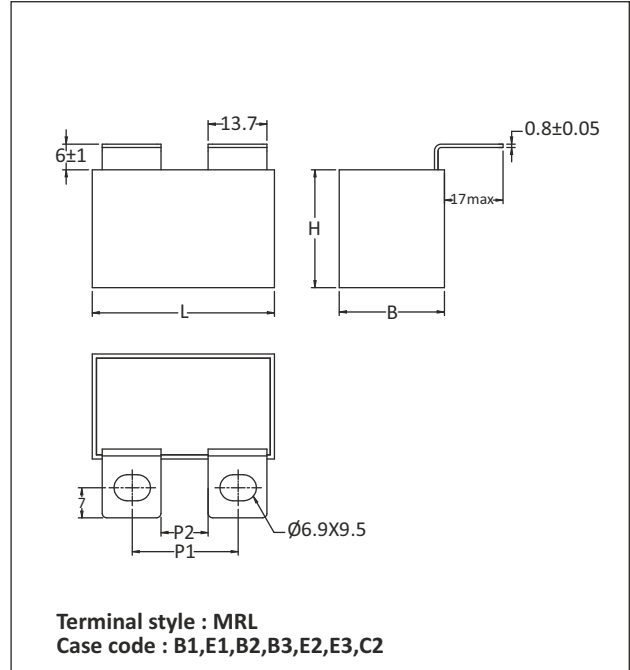
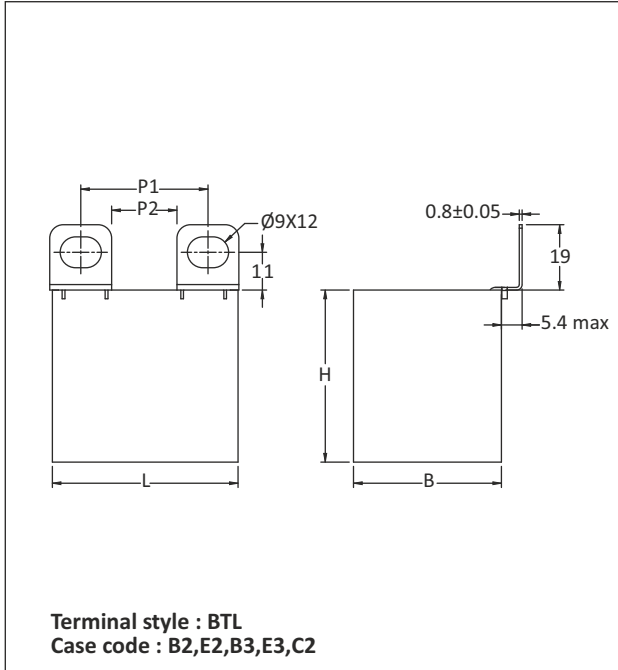

Dimensions in mm

For details see Case Code table on page 16 & 17

KPF

Capacitor Drawings and Terminal Styles

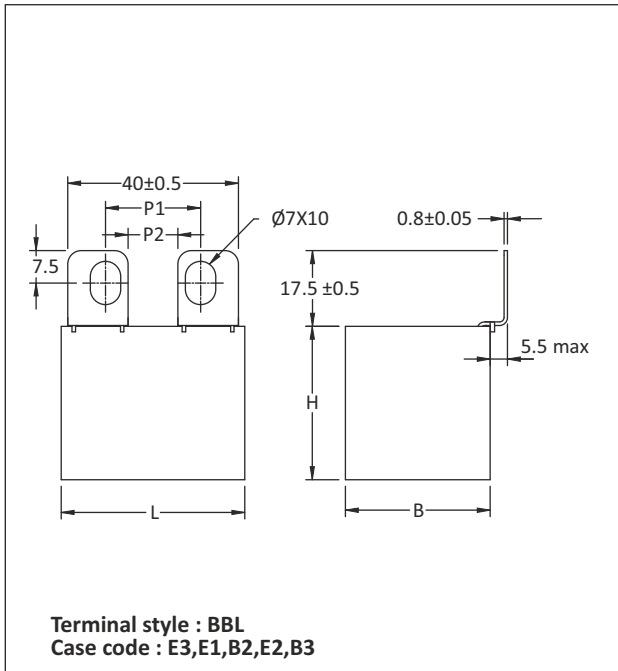

Dimensions in mm

For details see Case Code table on page 16 & 17

KPF

Table of Case Codes and Dimensions

Case Code	Dimensions in mm*			P1	P2	Terminal Styles
	B±1	H±1	L±1			
K2	11.0	20.0	32.0	27.5	–	DL
K3	13.0	22.0	32.0	27.5	–	DL
K4	14.0	24.0	32.0	27.5	–	DL
B1	17.0	29.0	41.5	37.5	–	FT,2P
B1	17.0	29.0	41.5	23.5	8.5	TL,RL,STL,SL
B1	17.0	29.0	41.5	22.0	8.5	MRL
B1	17.0	29.0	41.5	38.5	17.0	TP
B1	17.0	29.0	41.5	24.5	10.5	MTL
B1	17.0	29.0	41.5	23.0	9.0	VN
E1	20.0	36.0	42.0	37.5	–	FT,2P
E1	20.0	36.0	42.0	23.5	8.5	TL,RL,STL,SL
E1	20.0	36.0	42.0	22.0	8.5	MRL
E1	20.0	36.0	42.0	38.5	17.0	TP
E1	20.0	36.0	42.0	24.5	10.5	MTL
E1	20.0	36.0	42.0	22.0	11.5	BBL
E1	20.0	36.0	42.0	22.0	11.1	VT
E1	20.0	36.0	42.0	23.0	9.0	VN
B2	24.0	38.0	45.0	37.5	–	FT,2P
B2	24.0	38.0	45.0	23.5	8.5	TL,RL,STL,SL
B2	24.0	38.0	45.0	22.2	8.5	MRL
B2	24.0	38.0	45.0	38.5	17.0	TP
B2	24.0	38.0	45.0	24.5	10.5	MTL
B2	24.0	38.0	45.0	23.0	9.0	VN
B2	24.0	38.0	45.0	22.0	11.1	VT
B2	24.0	38.0	45.0	25.0	7.0	BTL
B2	24.0	38.0	45.0	22.0	11.5	BBL
E2	35.0	42.0	45.0	37.5	–	FT,3P
E2	35.0	42.0	45.0	27.0	11.5	TL,RL,STL,SL
E2	35.0	42.0	45.0	25.0	11.5	MRL
E2	35.0	42.0	45.0	38.5	17.0	TP
E2	35.0	42.0	45.0	27.0	13.0	MTL
E2	35.0	42.0	45.0	25.0	7.0	BTL
E2	35.0	42.0	45.0	22.0	11.1	VT
E2	35.0	42.0	45.0	23.0	9.0	VN
E2	35.0	42.0	45.0	22.0	11.5	BBL
B3	30.0	45.0	45.0	37.5	–	FT,3P
B3	30.0	45.0	45.0	26.50	11.5	TL,RL,STL,SL,VT,VN
B3	30.0	45.0	45.0	25.0	11.5	MRL
B3	30.0	45.0	45.0	38.5	17.0	TP
B3	30.0	45.0	45.0	27.0	13.0	MTL
B3	30.0	45.0	45.0	25.0	7.0	BTL
B3	30.0	45.0	45.0	22.0	11.5	BBL
E3	35.0	46.0	54.0	48.5	–	3P
E3	35.0	46.0	54.0	26.50	11.5	TL,RL,STL,SL
E3	35.0	46.0	54.0	25.00	11.5	MRL
E3	35.0	46.0	54.0	27.0	13.0	MTL
E3	35.0	46.0	54.0	68.5	–	AD
E3	35.0	46.0	54.0	55.0	28.0	CL
E3	35.0	46.0	54.0	37.0	19.0	BTL
E3	35.0	46.0	54.0	22.0	11.1	VT
E3	35.0	46.0	54.0	23.0	9.0	VN
E3	35.0	46.0	54.0	22.0	11.5	BBL
C2	43.0	50.0	54.0	37.0	19.0	BTL
C2	43.0	50.0	54.0	48.5	–	4P

* Refer to “Capacitor Drawing” on page 18 to 23

KPF

Table of Case Codes and Dimensions

Case Code	Dimensions in mm*			P1	P2	Terminal Styles
	B±1	H±1	L±1			
C2	43.0	50.0	54.0	26.50	11.5	TL,RL,STL,SL,BTL
C2	43.0	50.0	54.0	25.0	11.5	MRL
C2	43.0	50.0	54.0	27.0	13.0	MTL
C2	43.0	50.0	54.0	68.5	–	AD
C2	43.0	50.0	54.0	55.0	28.0	CL
C2	43.0	50.0	54.0	22.0	11.1	VT
C2	43.0	50.0	54.0	23.0	9.0	VN
C1	18.0	33.0	38.0	32.0	–	CT
C1	18.0	33.0	38.0	18.0	–	AB
C1	18.0	33.0	38.0	31.0	–	CR

* Refer to “Capacitor Drawing” on page 18 to 23

Precaution

1. These capacitors are not suitable for ‘across the line’ applications
2. VAC(rated) : Frequency should be less than 1000Hz
3. VDC(rated) : $1.4 \times V_{rms} + VDC$ should be less than rated VDC
4. MAX ESR = Typical ESR +30%