

HIGH VOLTAGE MULTILAYER CERAMIC CAPACITORS

DESCRIPTION:

RoHS compliant (*)

Capacitors 0805 to 6560

Rated voltage 1000V to 10KV

Dielectric Type I and II

SMD and leaded versions

** Non RoHS version still maintained for current applications.*



I. Foreword

The High voltage series is intended for such typical application as high voltage power supplies and high voltage multiplier circuits. Available in bare chips, they can be used in surface mounting or hybrid circuit applications. Their multilayer construction offers significant size and space saving advantage. Combination of standard case sizes may be obtained for special applications. They are suited for use in commercial, industrial and High-Rel military circuits.

II. Description

The capacitors here mentioned concern the voltage equal or higher than 1KV, in bare chips or leaded devices. The dielectrics used are from 2 types: ultra stable NP0 and X7R dielectrics.

Bare chips:



Radial leaded devices:

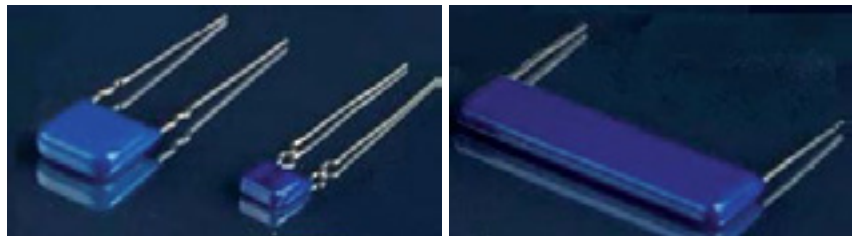

The standard wires are straight but on special request they can be bended to meet customer specification. Ask us for specific demand!

HIGH VOLTAGE MULTILAYER CERAMIC CAPACITORS

III. Capacitance Ranges

Case size	Rated Voltage	S Termination		Radial Leaded version Avail.
		NPO Dielectric	X7R Dielectric	
R15 = 0805	1000V	150pF to 1.0nF		
	1000V	10pF to 1nF	220pF to 18nF	
R18 = 1206	2000V	2pF to 390pF	150pF to 6.8nF	
	3000V	2pF to 39pF	150pF to 1nF	
S41 = 1210	1000V	10pF to 2.2nF	220pF to 47nF	
	2000V	150pF to 6.8nF		
S43 = 1812	1000V	68pF to 6.8nF	220pF to 150nF	
	2000V	68pF to 1.5nF	270pF to 15nF	
	3000V	2pF to 1.2nF	150pF to 10nF	
S47 = 2220	1000V	1nF to 12nF	10nF to 220nF	
	2000V	2pF to 120pF	1nF to 58nF	
	3000V	2pF to 120pF	150pF to 15nF	
	4000V	2pF to 120pF	150pF to 10nF	
	5000V	2pF to 120pF		

Available capacitance series (cf end of this chapter):
 NPO dielectric: Epsilon 12 in standard, Epsilon 24 upon request
 X7R dielectric: Epsilon 6 in standard, Epsilon 12 upon request

EXXELIA TEMEX reserves the right to modify herein specifications and information at any time when necessary to provide optimum performance and cost.

HIGH VOLTAGE MULTILAYER CERAMIC CAPACITORS

Case size	Rated Voltage	P Termination		Radial Leaded version Avail.
		NPO Dielectric	X7R Dielectric	
1515	1000V	470pF to 820pF	330pF to 12nF	✓
	2000V	240pF to 470pF	220pF to 2.7nF	✓
	3000V	100pF to 220pF	150pF to 1nF	✓
	4000V	12pF to 150pF	120pF to 470pF	✓
2020	1000V		680pF to 22nF	✓
	2000V		470pF to 6.8nF	✓
	3000V		390pF to 2.7nF	✓
	4000V		390pF to 2.2nF	✓
2520	1000V		1nF to 33nF	✓
	2000V		680pF to 10nF	✓
	3000V		330pF to 3.9nF	✓
	4000V		220pF to 1.8nF	✓
	5000V		120pF to 1.5nF	✓
3333	1000V	2.7nF to 5.6nF	22nF to 100nF	✓
	2000V	1.2nF to 4.7nF	4.7nF to 27nF	✓
	3000V	560pF to 1.8nF	2.2nF to 12nF	✓
	4000V	470pF to 1nF	1.5nF to 8.2nF	✓
	5000V	330pF to 680pF	820pF to 3.3nF	✓
	6000V	220pF to 470pF	470pF to 2.2nF	✓
4020	5000V		1.2nF to 5.6nF	✓
	6000V		470pF to 1.5nF	✓
	7000V		330pF to 1.2nF	✓
	8000V		470pF to 820pF	✓
	9000V		390pF to 680pF	✓
	10 000V		270pF to 560pF	✓
4040	1000V	4.7nF to 10nF	39nF to 120nF	✓
	2000V	3.3nF to 5.6nF	10nF to 47nF	✓
	3000V	1.8nF to 2.7nF	3.3nF to 18nF	✓
	4000V	1nF to 1.8nF	2.7nF to 8.2nF	✓
	5000V	680pF to 1nF	1.2nF to 5.6nF	✓
	6000V	390pF to 820pF	560pF to 3.3nF	✓
	7000V		560pF to 1nF	✓
	8000V		270pF to 820pF	✓
	9000V		240pF to 620pF	✓
	10 000V		220pF to 470pF	✓

Available capacitance series (cf end of this chapter):
 NPO dielectric: Epsilon 12 in standard, Epsilon 24 upon request
 X7R dielectric: Epsilon 6 in standard, Epsilon 12 upon request

EXXELIA TEMEX reserves the right to modify herein specifications and information at any time when necessary to provide optimum performance and cost

HIGH VOLTAGE MULTILAYER CERAMIC CAPACITORS

Case size	Rated Voltage	P Termination		Radial Leaded version Avail.
		NPO Dielectric	X7R Dielectric	
5440	1000V	8.2nF to 12nF	82nF to 220nF	✓
	2000V	4.7nF to 8.2nF	15nF to 68nF	✓
	3000V	2.2nF to 3.3nF	6.8nF to 27nF	✓
	4000V	1.5nF to 2.7nF	4.7nF to 12nF	✓
	5000V	1.nF to 1.8nF	2.7nF to 10nF	✓
	6000V	470pF to 1.2nF	330pF to 5.6nF	✓
6560	1000V		150nF to 390nF	✓
	2000V		39nF to 150nF	✓
	3000V		18nF to 56nF	✓
	4000V		8.2nF to 22nF	✓
	5000V		4.7nF to 18nF	✓
	6000V		2.7nF to 12nF	✓
	7000V		2.7nF to 6.8nF	✓
	8000V		2.7nF to 3.9nF	✓

Available capacitance series (cf end of this chapter):
 NPO dielectric: Epsilon 12 in standard, Epsilon 24 upon request
 X7R dielectric: Epsilon 6 in standard, Epsilon 12 upon request

These hereinabove tables define the standard products, other components may be built, don't hesitate to contact us (cf chapter VIII).

Capacitance series:

Epsilon 6: 10, 15, 22, 33, 47, 68

Epsilon 12: 10, 12, 15, 18, 22, 27, 33, 39, 47, 56, 68, 82

Epsilon 24: 10, 11, 12, 13, 15, 16, 18, 20, 22, 24, 27, 30, 33, 36, 39, 43, 47, 51, 56, 62, 68, 75, 82, 91

Are included their multiples and sub multiples of 10.

EXXEL A TEMEX reserves the right to modify herein specifications and information at any time when necessary to provide optimum performance and cost.

HIGH VOLTAGE MULTILAYER CERAMIC CAPACITORS

IV. Dimensions

SMD components

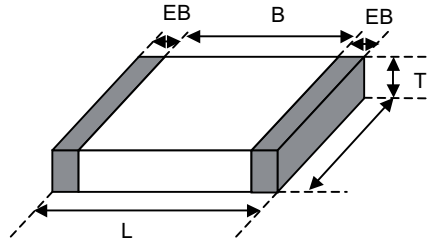

All dimensions in mm

Case size	S termination						
	L	Tol. (±)	W	Tol. (±)	T maxi	EB min	B min
R15 = 0805	2.0	0.2	1.25	0.2	1.45	0.2	0.7
R18 = 1206	3.2	0.3	1.6	0.2	1.8	0.3	1.5
S41 = 1210	3.2	0.3	2.5	0.2	2.6	0.3	1.6
S43 = 1812	4.6	0.3	3.2	0.3	3.0	0.3	2.5
S47 = 2220	5.7	0.4	5.0	0.4	3.0	0.3	3.5

Case size	L	Tol. (±)	W	Tol. (±)	Thickness maxi (T)										EB min	B Min	
					Voltage (kV)												
					1	2	3	4	5	6	7	8	9	10			
1515	3.8	0.38	3.8	0.38	3.9	3.9	3.9	3.9								0.3	2.22
2020	5.1	0.51	5.1	0.51	3.9	3.9	3.9	3.9								0.3	3.19
2520	6.4	0.64	5.1	0.51	3.9	3.9	4.5	4.5	4.5							0.3	4.36
3333	8.4	0.84	8.4	0.84	4.5	4.5	4.5	4.5	5.9	5.9						0.5	5.56
4020	10.2	1	5.1	0.51					4.5	4.5	5.1	5.1	5.1	5.1		0.5	7.2
4040	10.2	1	10.2	1	3.9	4.5	5.1	5.1	5.1	5.1	5.1	5.1	5.1	5.1		0.5	7.2
5440	13.7	1.4	10.2	1	4.5	5.1	5.1	5.1	6.4	6.4						0.5	10.3
6560	16.5	1.7	15.2	1.5	4.5	5.1	5.1	5.1	6.4	6.4	6.4	6.4				0.5	12.8

Regarding the thickness for exact values for each part number, please consult us.

HIGH VOLTAGE MULTILAYER CERAMIC CAPACITORS

Radial leaded components

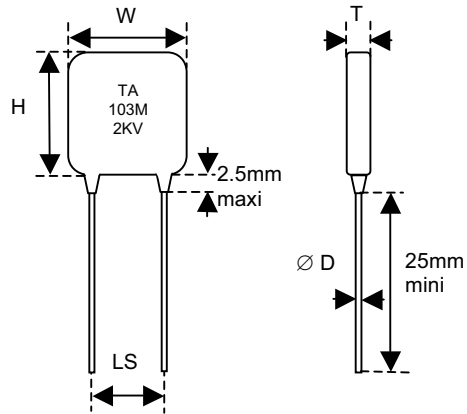

Case size	W maxi	H maxi	L.S. ±0.5	D ±10%	Thickness maxi (T)													
					Voltage (KV)													
					1	2	3	4	5	6	7	8	9	10				
1515	6.3	5.8	5.08	0.6	5.2	5.2	5.2	5.2										
2020	7.6	7.1	5.08	0.6	5.2	5.2	5.2	5.2										
2520	8.9	7.1	7.62	0.6	5.2	5.2	5.8	5.8	5.8									
3333	11.4	10.4	10.16	0.9	5.8	5.8	5.8	5.8	7.2	7.2								
4020	13.2	7.1	12.7	0.9						5.8	5.8	6.4	6.4	6.4	6.4			
4040	13.2	12.2	12.7	0.9	5.2	5.8	6.4	6.4	6.4	6.4	6.4	6.4	6.4	6.4	6.4			
5440	16.7	12.2	15.24	0.9	5.8	6.4	6.4	6.4	6.4	7.7	7.7							
6560	19.5	17.2	17.78	0.9	5.8	6.4	6.4	6.4	6.4	7.7	7.7	7.7	7.7					

All dimensions in mm
For exact values regarding the thickness, please consult us.

HIGH VOLTAGE MULTILAYER CERAMIC CAPACITORS

V. Marking

Note: the marking is only available for leaded capacitors.

Size	Marking codes	Example
1515 2020	Cap Code Tolerance Code	103 M
2520 4020	Cap Code + Tolerance Code Rated voltage value	103M 1KV
Other sizes	« TA » logo Cap Code + Tolerance Code Rated voltage value	TA 103M 2KV

VI. Dielectric characteristics

Description	NP0 dielectric (class 1)	X7R dielectric (class 2)
CECC	1B CG	2R1
EIA	COG	X7R
Temex Ceramics Code	N	X
Operating temperature range	-55°C / +125°C	-55°C / +125°C
Storage temperature range	-55°C / +125°C	-55°C / +125°C
Temperature coefficient	0 ± 30ppm / °C	NA
Maximum ΔC/C over Temperature range without voltage applied	NA	± 15%
Ageing	None	≤2.5% per decade hour
Dissipation Factor (D.F.)	≤ 0.15%	≤ 2.5%
Voltage proof	Ur ≥ 1000V: 1.2 x Ur	Ur ≥ 1000V: 1.2 x Ur
Insulation Resistance (IR) @ 25°C (Under Ur or under 1000V DC if Ur > 1000V DC)	> 1000V: 100GΩ or 1000Ω.F*	> 1000V: 100GΩ or 1000Ω.F*
Insulation Resistance (IR) @ 125°C (Under Ur or under 1000V DC if Ur > 1000V DC)	> 1000V: 10GΩ or 100Ω.F*	> 1000V: 10GΩ or 100Ω.F*
Measurement Conditions for C and D.F. @ 20°C	≤ 1000pF: 1MHz / 1Vrms (no bias) > 1000pF: 1KHz / 1Vrms (no bias)	≤ 100pF: 1MHz / 1Vrms (no bias) > 100pF: 1KHz / 1Vrms (no bias)

(*): whichever is the less.

EXCEL A TEMEX reserves the right to modify herein specifications and information at any time when necessary to provide optimum performance and cost.

HIGH VOLTAGE MULTILAYER CERAMIC CAPACITORS

VII. Electrical characteristics

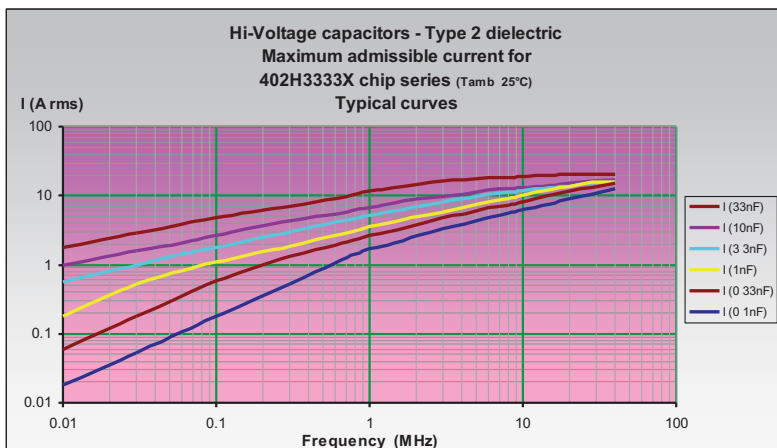
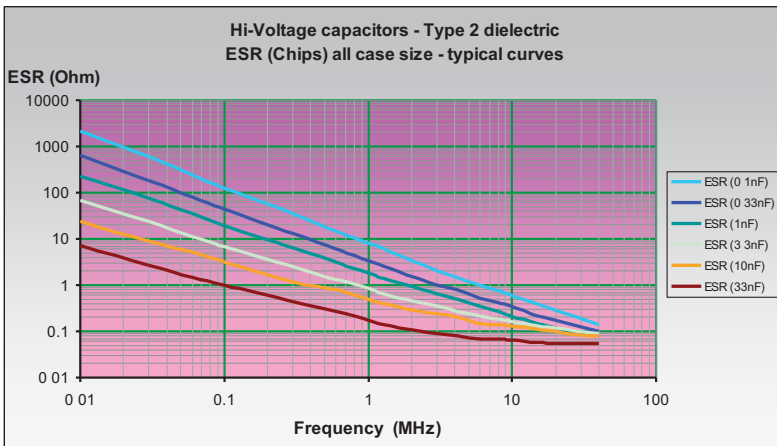
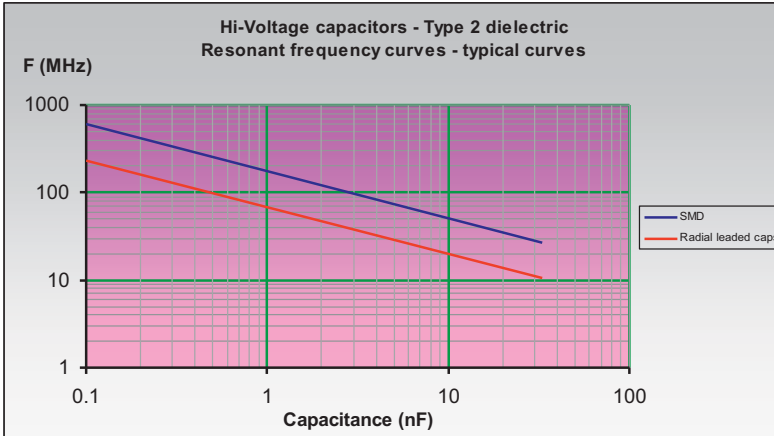

The ESR (Equivalent Serial Resistance) curves are given here for SMD (chips) capacitors. Regarding the curves for the leaded capacitors, they are rather the same.

Indeed, due to the resistivity of the raw material used and the wire diameters, the resistance of the wires is much lower than the ESR of the chips. So, in a first approach, their influence can be considered as negligible.

These typical curves are an example of admissible currents for one family of chip capacitors. For other curves and products or for further information, please contact us.

Note: for the calculations, we have considered that the terminations are directly connected to an infinite heat sink. In other words, the thermal resistance of the circuit itself which depends of its type and design has not been taken into account. Moreover, the ambient temperature taken is 25°C.

HIGH VOLTAGE MULTILAYER CERAMIC CAPACITORS

VIII. Termination types

Description	P (RoHS)	S (RoHS)	R (RoHS)	R (non RoHS)
Chip (SMD)	✓	✓	-	-
Radial wires	-	-	✓	✓
Materials	Pure Ag Or AgPd	100% tinned Nickel barrier	100% tinned Copper	Sn(70%) Pb(30%) plated Copper
Magnetic status	Non magnetic	Magnetic	Non magnetic	Non magnetic
Lead status (% of Pb)	0%	0%	0%	30% of the plated layer

IX. Special products

As standard products can't meet all the specificities of all applications, special applications may require special features (higher voltage, burn-in, dimensions, coating, leading, marking...) not described in this catalogue.



Based on the “state of the Art”, and our knowledge of the technology, our Engineers may study at your request all special components to meet your application.
Please, consult us for more information.

HIGH VOLTAGE MULTILAYER CERAMIC CAPACITORS

X. How to order

802	H	6560	X	182	K	P	E	-RoHS
Rated Voltage	Family	Size	Dielectric	Capacitance	Tolerance (*)	Termination	Packaging	RoHS Compliance (**)
1st two digits are significant; third digit denotes number of zeros	Left blank	R15 R18 S41 S43 S47	N = NP0 X = X7R	1st two digits are significant; third digit denotes number of zeros	For N dielectric A ($\pm 0.05\text{pF}$) B ($\pm 0.1\text{pF}$) C ($\pm 0.25\text{pF}$) D ($\pm 0.5\text{pF}$)	S	Left blank: Blister boxes E: Tape and reel for chips	If left blank non RoHS compliant
Examples: 201 = 200V 501 = 500V 102 = 1000V 202 = 2000V	Family H	Size 1515 2020 2520 3333 5440 6560		Examples: 101 = 100pF 472 = 4.7nF 683 = 68nF 104 = 0.1 μF	J ($\pm 5\%$) K ($\pm 10\%$) M ($\pm 20\%$) For X dielectric K ($\pm 10\%$) M ($\pm 20\%$)	Termination P R		

(*): capacitance values lower than 10pF, tolerances A, B, C and D apply. For capacitance values equal or higher than 10pF, tolerances F, G, J and K apply.

(**): For "Radial Leaded (R)" capacitors, both RoHS and non-RoHS versions exist. This is due to the wishes of some customers who still need non-RoHS components in their applications. This suffix must be required for RoHS compliance.

For "P", "A" and "S" terminations, only the RoHS version exists. The RoHS suffix can be added for information.

HIGH VOLTAGE MULTILAYER CERAMIC CAPACITORS

XI. Packaging

According to their dimensions, the components can be delivered in tape or individually protected in “blister” boxes. Please, refer to the following table:

Tape and reel (SMD components):

Case size	Qty per reel *	Tape type
0805 R15	3000 4000	8mm
1206 R18	3000 4000	8mm
1210 S41	2000 4000	8mm
1812 S43	500 1000	12mm
2220 S47	500 1000	12mm
H1515	500	12mm
H2020	500 1000	12mm
H2520	400	12mm

* Depending upon the thickness of the components, please consult us.

Dimensions diameter reel (in mm)

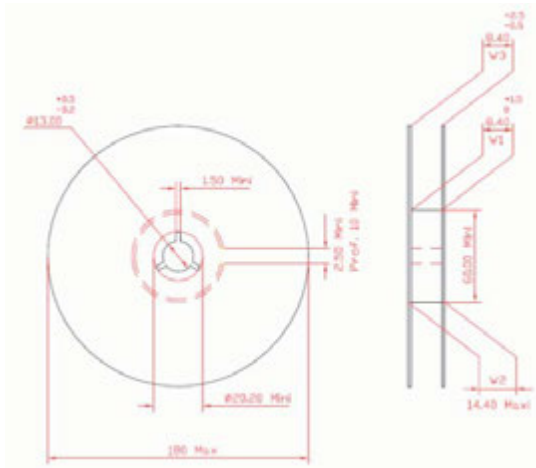

Tape type: 8mm

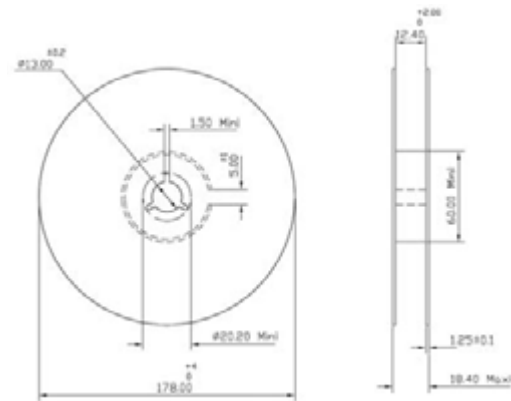

Tape type: 12mm

Regarding the reels and tape dimensions, they are compliant to the IEC 60286 3 standard.

“Blister” Boxes (SMD and leaded components):

Case sizes for 1515 and above can be delivered with plastic “blister” boxes especially designed to protect the components which could be large and quite heavy. Depending upon the termination (with or without connection) and the size, the number of the parts in each box is defined. Please, consult us for more details.