

FP-10-400

Highlights

- Conduction cooled
- Polypropylene dielectric
- Self-healing
- Operating frequency 100 KHz
- Maximum operating core temperature 85°C
- Capacitance tolerance $\pm 10\%$
- Flame retardant UL94 - V0, ROHS compliant



Standard Capacitor Values

Rated Voltage Vrms	Nominal capacitance MFD at 1KHz	Max current Irms	Max power Kvar	Frequency KHz	ESR mΩ	Dimensions mm			Case Code	Terminal Style	Ordering Code
						B	H	L			
600	6.50	1000	400	27-62	1.2	100	54	100	G1	5H	SP06U500600A80G1005HK01
	8.50	1000	400	20-47	1.0	100	54	100	G1	5H	SP08U500600A80G1005HK01
	10.00	1000	400	18-40	0.8	100	54	100	G1	5H	SP000100600A80G1005HK01
500	20.00	1000	400	13-15	0.6	100	54	100	G1	5H	SP000200500A80G1005HK01
400	40.00	1000	400	10	0.4	100	54	100	G1	5H	SP000400400A80G1005HK01

Capacitor Drawing and Terminal Style

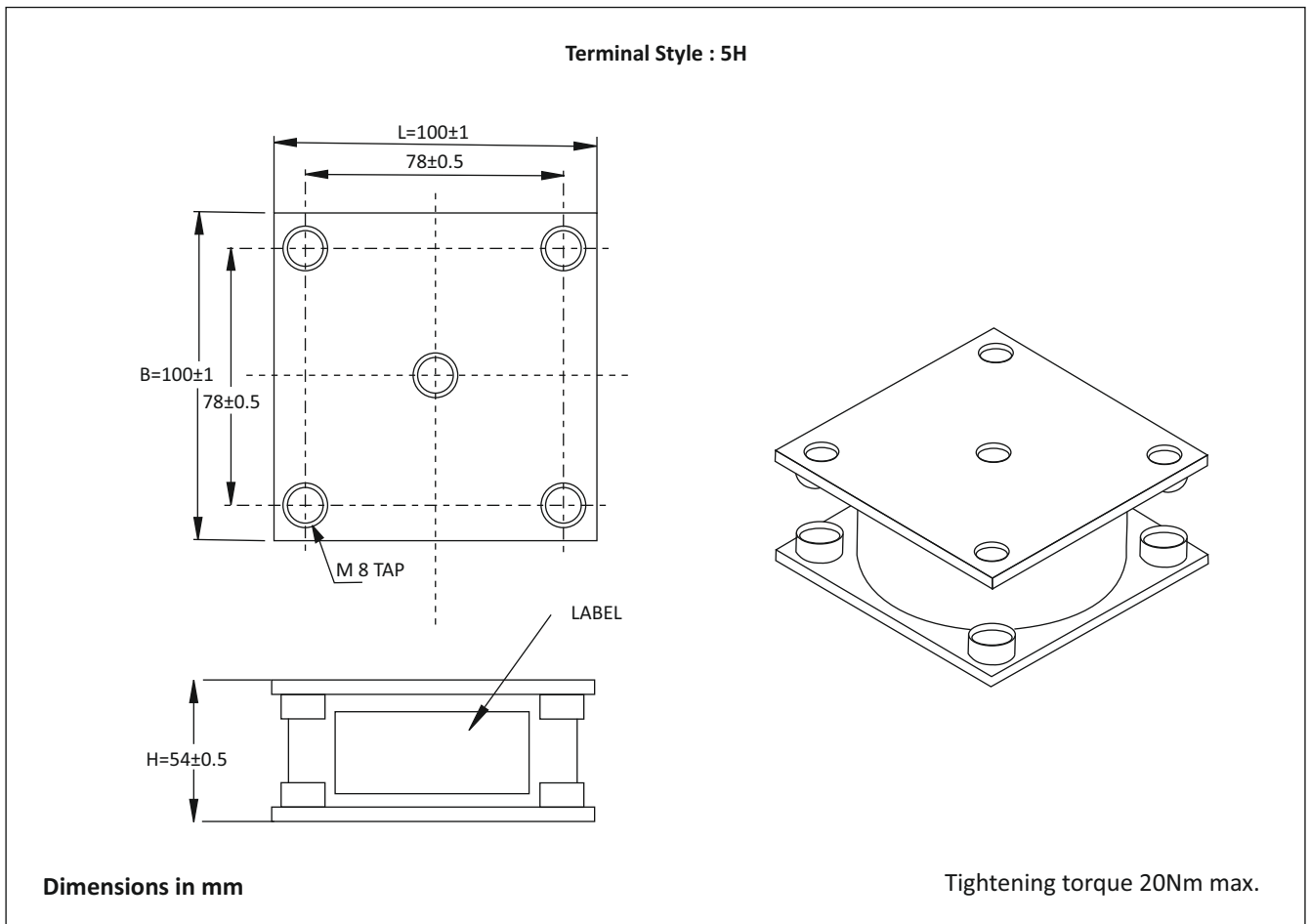

FP-10-400

Frequency Derating

—●— Voltage —■— Current —▲— Power

