

MICROWAVE TUNING ELEMENTS

RoHS COMPLIANT

Description

Economical means of introducing a variable reactance to microwave circuits such as waveguides, filters, cavities and other resonant structures

High resolution tuning

Self-locking constant torque drive mechanism

Excellent tuning stability

Low dynamic noise

One handed adjusting/tuning, no need for locking nut

Available with Gold, Silver plating and chromate finish

Metallic, dielectric, resistive types available

Adjustments in applications from L to Ka band and beyond

High Reliability versions are available on special order

Custom design upon request

ROHS compliant



Applications

Comb-line and inter-digital filters

Coaxial structures

Waveguide circuitry

Gunn oscillators

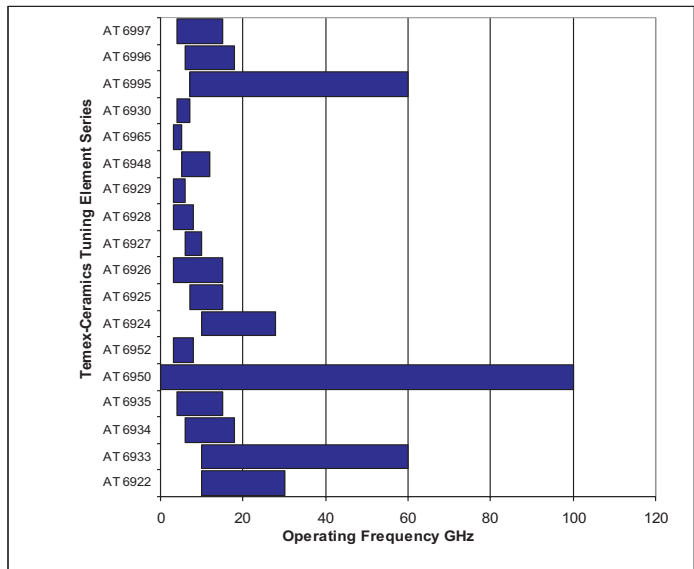

Impedance transformersSpace applications

I. Microwave tuning elements

Tuning Elements consist of a brass mounting bushing with a rotor of the same material including a tuning rod made of metallic or dielectric or absorbent material and a nut.

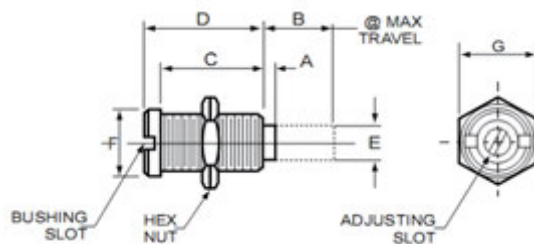

MICROWAVE TUNING ELEMENTS

RoHS COMPLIANT

I.1 Metallic tuning elements

Metallic Tuning Elements consist of a brass mounting bushing with an integral tuning rotor of the same material and a nut. Bushing is gold plated, rotor and nut are passivated.

Optional materials and plating are available upon request.

Models and dimensions in mm

P/N	Frequency Band	Bushing Thread UNS	A	B	C	D	Φ E	Φ F	G
AT 6924-0 SL ROHS	X to K	.120-80	0	3.8	5.1	6.0	1.8	3.4	4.0
AT 6924-1 SL ROHS			1.2	1.9	2.2	3.1			
AT 6924-2 SL ROHS			0	1.9	5.1	6.0			
AT 6924-3 SL ROHS			0	0.8	2.2	3.1			
AT 6925-0 SL ROHS	C and X	.190-64	0	3.8	5.4	6.4	3.2	5.3	5.5
AT 6925-1 SL ROHS			0	0.6	2.2	3.2			
AT 6925-3 SL ROHS			3.3	7.1	5.4	6.4			
AT 6925-7 SL ROHS			1.1	4.9	5.4	6.4			
AT 6925-8 SL ROHS			0.2	2.0	3.2	4.3			
AT 6925-9 SL ROHS			0	2.3	6.5	7.5			
AT 6926-0 SL ROHS			0	2.7	4.6	5.3			
AT 6926-1 SL ROHS			0	0.7	2.4	3.2			
AT 6926-4 SL ROHS			2.3	8.8	5.5	9.1			
AT 6926-5 SL ROHS			.234-64	0.6	2.7	4.0			
AT 6926-6 SL ROHS	2.6	11.5		5.4	11.5				
AT 6926-7 SL ROHS	1.9	4.6		4.6	5.3				
AT 6926-9 SL ROHS	0	2.7		5.5	9.1				
AT 6926-10 SL ROHS	0	4.6		5.5	9.1				
AT 6927-0 SL ROHS	C and X	.234-64	0	6.5	5.5	9.1	4.1	6.8	7.0
AT 6928-0 SL ROHS	C		0	8.8	5.4	11.5	4.1	6.8	7.0
AT 6928-2 SL ROHS	C		6.1	8.8	4.6	5.3	4.1	6.8	7.0
AT 6929-0 SL ROHS	C	.190-64	0	11.4	13	14	3.2	5.3	5.5
AT 6948-0 SL ROHS	C and X	.312-64	0	5.9	8.2	9.2	5.3	9.5	10.0
AT 6965-0 SL ROHS	L and S	.469-32	0	12.7	17.3	18.3	8.8	13.5	14.3

Custom dimensions are available upon request

I.2 Dielectric tuning elements

Dielectric Tuning Elements are used whenever the lowest loss tuning for high frequency applications is required. When dielectric rod is introduced into a cavity, the self resonant frequency is lowered due to the cavity "appearing" larger.

The basic dielectrics used in Temex-Ceramics Microwave Tuning Elements are sapphire, quartz and alumina.

MICROWAVE TUNING ELEMENTS

RoHS COMPLIANT

Electrical properties of each dielectric material are:

Dielectric Material	Approximate Dielectric Constant @ 10 GHz	Approximate Dissipation Factor @ 10 GHz
Sapphire	9.9	0.0001
Quartz	3.8	0.0001
Alumina	9.7	0.0002

Models and dimensions in mm

P/N	Rod Material	Frequency Band	Bushing Thread UNS	A	B	C	D	ΦE	ΦF	G
AT 6933-0 SL ROHS	Sapphire	X and K	.120-80	0.6	4.3	5.1	6.0	1.6	3.4	4.0
AT 6933-1 SL ROHS	Sapphire			0	3.3	5.1	6.0	0.9		
AT 6933-2 SL ROHS	Quartz	K		0.6	4.3	5.1	6.0	1.6		
AT 6934-0 SL ROHS	Sapphire	C, X and K		0.3	3.0	4.6	5.3	3.9		
AT 6935-0 SL ROHS	Sapphire	X and K	.234-64	0.3	6.8	5.5	9.1	3.9	6.8	7.0

Custom dimensions are available upon request

1.3 Resistive tuning elements

Resistive Tuning Elements provide a consistent and accurate means of attenuating microwave energy. Rod made of magnetically loaded epoxy exhibits broadband lossy properties.

Models and dimensions in mm

P/N	Frequency Band	Bushing Thread UNS	A	B	C	D	ΦE	ΦF	G
AT 6950-0 SL ROHS	Broad Band	.120-80	0.6	4.3	5.1	6.0	1.6	3.4	4.0
AT 6950-1 SL ROHS			0	3.3	5.1	6.0	2.0	3.4	4.0
AT 6952-0 SL ROHS		.234-64	0	6.4	5.5	9.1	3.9	6.8	7.0

Custom dimensions are available upon request

1.4 mm Wave tuning elements

The millimeter Wave Tuning Elements are higher frequency versions of both Tuning Elements described in this data sheet.

Part number: **AT 6922 ROHS**. Bushing and rotor are made of brass gold plated.

Usage in the frequency bands X to K. Bushing can be mounted with solder, epoxy or press-fit.



MICROWAVE TUNING ELEMENTS

RoHS COMPLIANT

Recommended rotor tuning tool AT 8762

II. Tuning rotors

Extended range metallic and dielectric rotors are used where direct insertion of the tuning element is desired.

Taps designed specifically to insure proper fit are available.

II.1 Metallic tuning rotors

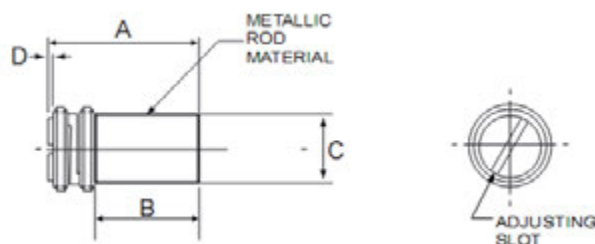

Models made of brass and dimensions in mm

P/N	Thread	A	B	Φ C	D	Slot W x L
AT 6501-3 ROHS	M 1.5 x 0.25	4.4	2.3	1.1		0.25 x 1.1
AT 6501-0 ROHS		5.4	3.3			
AT 6501-1 ROHS	M 2.5 x 0.25	4.4	2.3	2.1	0.4	0.4 x 1.9
AT 6501-2 ROHS		7.7	5.6			
AT 6995-0 ROHS		3.1	0.8			
AT 6995-1 ROHS	.094-80 UNS	4.2	1.9	1.8	0.5	0.4 x 1.5
AT 6995-2 ROHS		6.1	3.8			
AT 6996-1 ROHS		6.4	3.8			
AT 6996-2 ROHS		9.7	7.1			
AT 6996-3 ROHS		14.0	11.4			
AT 6996-4 ROHS	.156-64 UNS	3.2	0.6	3.2	0.25	0.5 x 3.0
AT 6996-5 ROHS		7.5	4.9			
AT 6996-6 ROHS		4.6	2.0			
AT 6996-8 ROHS		4.9	2.3			
AT 6997-0 ROHS		14.1	11.5			
AT 6997-1 ROHS		5.3	2.7			
AT 6997-2 ROHS	.190-64 UNS	9.1	6.5	4.1	0.25	0.5 x 3.7
AT 6997-3 ROHS		11.4	8.8			
AT 6997-4 ROHS		3.3	0.7			
AT 6997-5 ROHS		7.2	4.6			

Custom dimensions are available upon request

MICROWAVE TUNING ELEMENTS

RoHS COMPLIANT

II.2 Dielectric tuning rotors



Models with dielectric rod and dimensions in mm

P/N	Rod material	Thread	A	B	Φ C	D	Slot W x L
AT 6930-4 ROHS	Sapphire	.094-80	5.8	2.5	0.9	0.5	0.4 x 1.5
AT 6930-8 ROHS		UNS	6.6	3.5	1.6	0.5	

Custom models and dimensions are available upon request.

III. DRO tuners

DRO tuners are precision components designed exclusively for tuning dielectric resonator devices such as filters and oscillators.

Rod is made of Invar silver plated and disk made of brass silver plated. Different disk diameters are available.

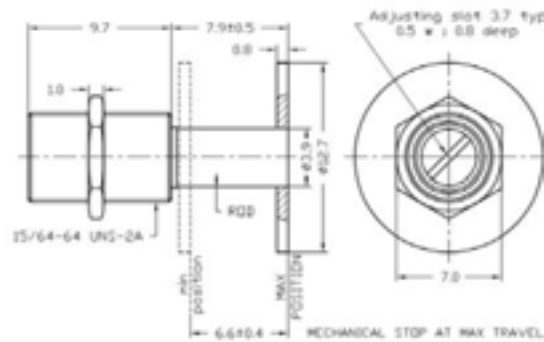

Models and dimensions in mm

P/N	Nominal Frequency	Disk diameter
AT 4010-1 ROHS	2 GHz	24.6
AT 4011-1 ROHS	3 GHz	19.0
AT 4012-1 ROHS	4 GHz	12.7
AT 4012-2 ROHS		15.9

Custom dimensions are available upon request

MICROWAVE TUNING ELEMENTS

RoHS COMPLIANT

IV. Mechanical and general specifications

SERIES	Bushing Thread	Tap P/N	Recommended Tap Drill (mm)	Rotational Rotor Torque (cm.N)	Max Mounting Torque (cm.N)	Max Nut Mounting Torque (cm.N)
AT 6924 ROHS	.120- 80 UNS	AT 7060	2.75	0.2 to 2.0	7.0	10.0
AT 6925 ROHS	.190-64 UNS	AT 7061	4.45	0.3 to 2.8	21.0	30.0
AT 6926 ROHS	.234-64 UNS	AT 7062	5.50	0.7 to 3.5	35.0	50.0
AT 6927 ROHS	.234-64 UNS	AT 7062	5.50	0.7 to 3.5	35.0	50.0
AT 6928 ROHS	.234-64 UNS	AT 7062	5.50	0.7 to 3.5	35.0	50.0
AT 6929 ROHS	.190-64 UNS	AT 7061	4.45	0.3 to 2.8	21.0	30.0
AT 6933 ROHS	.120- 80 UNS	AT 7060	2.75	0.2 to 2.0	7.0	10.0
AT 6934 ROHS	.234-64 UNS	AT 7062	5.50	0.7 to 3.5	35.0	50.0
AT 6935 ROHS	.234-64 UNS	AT 7062	5.50	0.7 to 3.5	35.0	50.0
AT 6948 ROHS	.312-64 UNS	AT 7065	7.55	0.7 to 5.0	84.0	70.0
AT 6950 ROHS	.120- 80 UNS	AT 7060	2.75	0.2 to 2.0	7.0	10.0
AT 6952 ROHS	.234-64 UNS	AT 7062	5.50	0.7 to 3.5	35.0	50.0
AT 6965 ROHS	.469-32 UNS	AT 7066	11.1	0.7 to 5.6	168.0	140.0

Recommended rotor tuning tool: AT 8777

SERIES	Rotor Thread	Tap P/N	Recommended Tap Drill (mm)	Recommended Tuning Tool P/N
AT 6501-3 ROHS	M1.5 x 0.25	AT 7071	1.25	AT 8762
AT 6501-0, -1, -2 ROHS	M2.5 x 0.25	AT 7070	2.25	AT 8777
AT 6995 ROHS	.094-80 UNS	AT 7064	2.05	
AT 6996 ROHS	.156-64 UNS	AT 7059	3.55	
AT 6997 ROHS	.190-64 UNS	AT 7061	4.45	

Precautions to use rotor tunings:

Typical drilling diameter is the tap core diameter + 0.1 mm

Flange of machined threads has to be perfect, very smooth, without metallic burrs.

Use recommended tuning tool.

Before screwing the rotor, find the first thread by turning the anti-clockwise.

MICROWAVE TUNING ELEMENTS

RoHS COMPLIANT

V. Packaging

Parts are delivered in bulk.

VI. How to order

Tuning elements

Reference	ROHS
------------------	-------------

Examples	AT 6924-3 SL	ROHS
	AT 6922	ROHS

Tuning rotors

Reference	ROHS
------------------	-------------

Examples	AT 6995-2	ROHS
	AT 6501-3	ROHS

DRO tuners

Reference	ROHS
------------------	-------------

Example	AT 4011-1	ROHS
---------	-----------	------